

Horten Ho 229 V3

Deluxe Short Kit

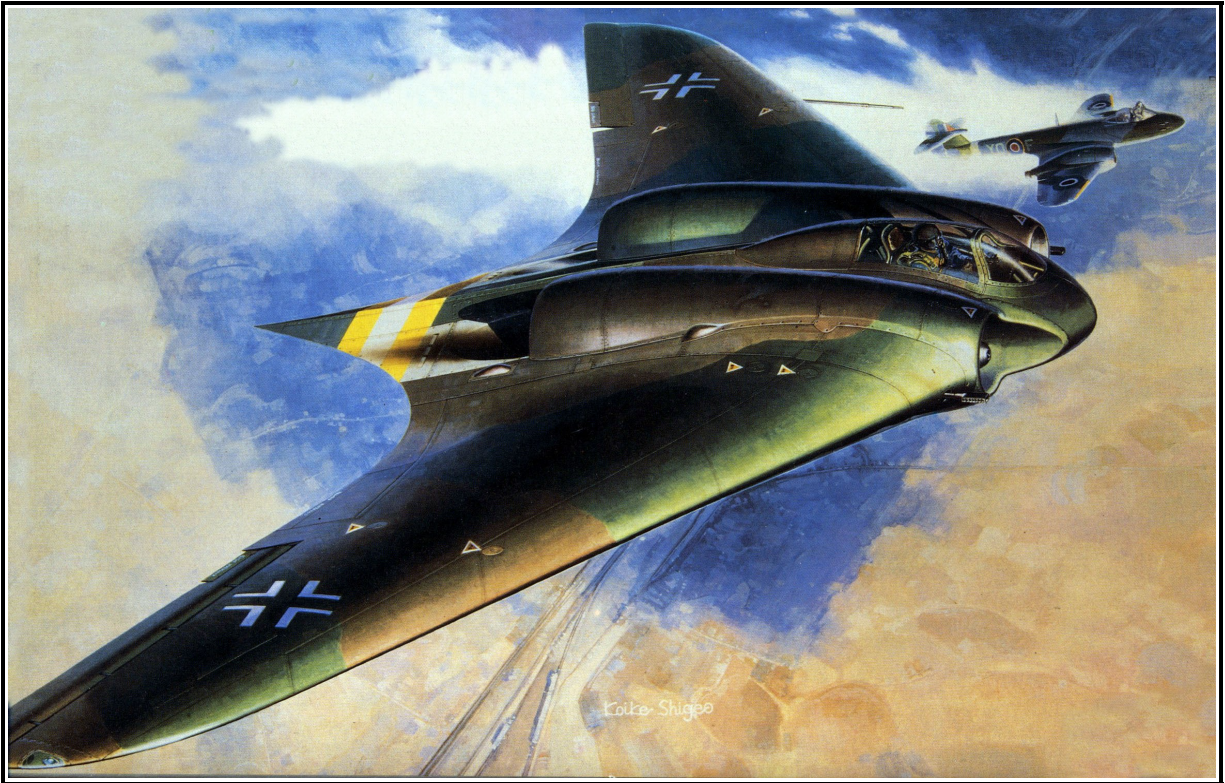

a Radio Controlled Model
in 1/8 Scale

Design by Gary Hethcoat

Copyright 2007
Aviation Research
P.O. Box 9192, San Jose, CA 95157
<http://www.wingsontheweb.com>
Email: gary.hethcoat@gmail.com
Phone: 408-660-0943

Table of Contents

1	General Building Notes.....	4
1.1	Getting Help.....	4
1.2	Laser Cut Parts.....	4
1.3	Electronics.....	4
1.4	Building Options.....	4
1.4.1	Removable Outer Wing Panels.....	4
1.4.2	Drag Rudders.....	4
1.4.3	Retracts.....	5
1.4.4	Frise Style Elevons.....	5
1.5	Motor/Speed Controller Choices.....	5
1.6	Building Guide Photos.....	5
2	Center Section (Fiberglass Version).....	6
2.1	Working with Fiberglass Parts.....	6
2.1.1	Bonding to Fiberglass.....	6
2.1.2	Fiberglass and Shop Safety.....	6
2.2	Center Section Jig.....	7
2.3	Front Spar and Ribs.....	7
2.4	Intake Duct Installation.....	11
2.5	LiPo Battery Attachment.....	12
2.6	Installing Ribs 3A.....	12
2.7	Leading Edge Installation.....	13
2.8	Retract Installation.....	14
2.9	Attaching the Framework to the Upper Shell.....	15
2.10	Fan Installation.....	16
2.11	Batteries.....	18
2.12	Connecting it all Together.....	18
2.12.1	Battery Connection.....	18
2.13	Rear Duct.....	19
2.14	Rear Duct Fairing.....	20
3	Outer Wing Panels.....	21
3.1	Laminating the Rib Doublers.....	21
3.2	Laying Down the Ribs.....	22
3.2.1	Elevon Servo Conduit.....	23
3.3	Installing the Laminated Spars.....	24
3.4	Leading Edge & Sheeting.....	26
4	Completing the Outer Wing Panels.....	30
4.1	Fitting the outer wing panels.....	30
4.2	Determining Attachment Method.....	30
4.3	Jigging the Outer Wing Panels.....	32
4.4	Elevon Servo Installation.....	34

4.5 Drag Rudder Construction (optional).....	36
Lower Outer Wing Panel Sheeting.....	39
4.6 Wing Tips.....	40
4.7 Cutting out and Hinging the Frise-style Elevons.....	40
4.8 Flap Construction (optional).....	42
5 Closing the center section.....	44
5.1 Preparing the center section lower shell.....	44
5.1.1 Nose seam backing.....	44
5.2 Fan Access Hatches.....	44
5.3 Outer Wing Panel Attachment.....	45
5.4 Attaching the Lower Shell.....	45
5.5 Finishing the Center Section.....	46
6 Finishing.....	48
6.1 Finishing Methods.....	48
6.2 Finishing the Center Section.....	48
6.3 Finishing the Outer Wing Panels.....	48
6.4 Paint & Markings.....	48
7 Trimming for Flight.....	50
7.1 Extension Tubes.....	50
7.2 Center of Gravity.....	51
7.3 Balancing Method.....	51
7.4 Recommended Control Throws.....	53
7.5 Ground Sit (ROG version).....	53
8 Flying the Ho 229.....	54
8.1 General Flying Characteristics.....	54
8.2 Aerobatics.....	54
8.3 Bungee Flying.....	54
8.4 Flying from a runway (ROG).....	55
8.4.1 Takeoff Procedures (ROG version).....	55
8.5 Approach and Landing.....	55
8.6 More Info.....	56
8.6.1 RCSB Thread.....	56
8.7 Yahoo Group "Ho229".....	56
8.7.1 Ezone Thread.....	56
8.7.2 Phone and "Snail Mail".....	56

1 General Building Notes

This model features mostly conventional construction methods and so should present few problems to the experienced builder. This is not a beginner's model. If you have limited building and flying experience, it is strongly recommended that you start with a more appropriate model and work up to the Ho 229.

1.1 Getting Help

If you need help or advice, please don't hesitate to contact us. Email and phone are listed on the title page.

1.2 Laser Cut Parts

Most of the laser cut parts can be gently broken free of the sheet. Be careful, though, some parts will come out cleaner if you cut through the little "breaks" with a hobby knife before removing the part from the sheet. This is particularly true of the lightening holes in the ribs.

1.3 Electronics

If this is your first high-powered electric model, proceed with extreme caution when handling, soldering and connecting batteries and speed controllers. A short or reversed connection can **FRY** some very delicate and expensive equipment! When soldering connectors onto LiPo batteries, work with one wire at a time and make sure the other is well insulated. Shorting these batteries will cause damage, and it is very easy to do if you work with both wires at the same time. Make absolutely sure you have the connections right before applying battery power to the speed controller.

1.4 Building Options

1.4.1 Removable Outer Wing Panels

The outer wing panels can be made removable for ease of transport. If you choose to do this, make sure whatever attachment method you use is secure. A recommended method is shown, but others are possible. Depending on the attachment method you use, it may be advisable to use packing tape on the lower seam before flight.

1.4.2 Drag Rudders

The outer drag rudders used on the full size are shown on the plans. They are advisable if you plan to build a ROG version to be used on a narrow runway.

These are your only method of controlling the model's flightpath in a crosswind landing on a runway.

1.4.3 Retracts

Keep in mind that retracts will add significantly to the finished weight. There is a CG shift to consider as the nose wheel retracts.

1.4.4 Frise Style Elevons

See the plans. These have been used on the prototype model. It is believed they offer some advantage in turning. However, experience has shown them to be quite vulnerable to damage when belly landing on grass. They tend to catch in the grass. I would recommended these only for an ROG model.

1.5 Motor/Speed Controller Choices

The model was designed around the Wemotec Mini-fan 480 (69mm) units. There are similarly sized units available from other manufacturers also. The duct brackets are designed for this size fan, though, so make sure whatever you use has the exact same inside diameter as these units. The prototype used the HET-RC Typhoon EDF 2W-20 (700 Watt) motors and SPT 80 Amp controllers. A good source for fans, motors and speed controllers is Warbirds-RC.com, <http://www.warbirds-rc.com/> They have good prices and we've received excellent service from them.

1.6 Building Guide Photos

Some of the photos may not be all that clear in the printed building guide. A downloadable PDF version of the guide is available on the Yahoo group (see references at the end of this document). The photos are clearer (and in color!) when viewed on a computer.

2 Center Section (Fiberglass Version)

2.1 Working with Fiberglass Parts

The fiberglass parts are made from West Systems epoxy and fiberglass cloth. Before doing anything else, the parts should be washed to remove any waxy residue from the mold release agent. Acetone is ideal for this, but it is a dangerous chemical, so please use adequate skin and lung protection if you use it. You can also just use a wash of strong detergent and hot water for a safer alternative. The edges of the parts may be sharp, so a pair of gloves is advisable. The parts also need to be trimmed. The leading edge area on both upper and lower halves must be trimmed to the cut line molded into the fiberglass. If you don't see a cut line, the parts may have already been trimmed. In that case test fit them and trim if necessary. The aft area (bat tail) shouldn't need trimming. The sides will be trimmed after gluing the whole thing together.

2.1.1 Bonding to Fiberglass

The best adhesive to use is the same epoxy the parts are made from, West Systems epoxy. It is a bit expensive, but it is very high quality. It has been our epoxy of choice for many years. CA glue will also bond to the parts, but the bond is weaker and more brittle than with epoxy. The parts should be roughed up with sandpaper no matter what glue you use.

2.1.2 Fiberglass and Shop Safety

Always wear gloves and a dust mask when cutting or grinding fiberglass parts. The dust is hazardous to both skin and lungs. Getting the dust into an open wound can cause a very painful infection. Breathing the dust can cause serious lung damage from the glass fibers and epoxy dust. Don't use the paper medical masks, they're nearly useless as they don't provide a good seal. Most home centers have rubber dust masks with a fiber filter, these are much more effective. Eye protection is also advisable as the dust and glass fibers can also get into your eyes.

2.2 Center Section Jig

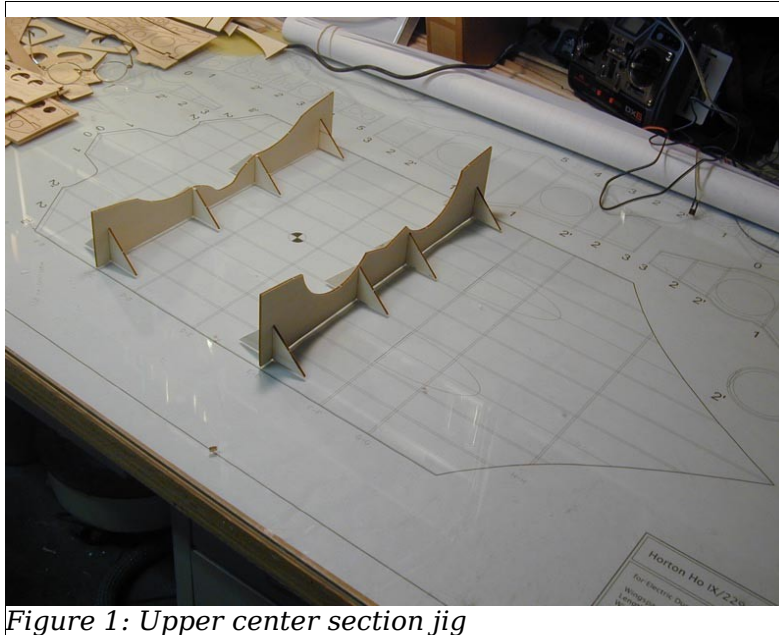

Figure 1: Upper center section jig

Start the center section construction by attaching the upper jig to the building board. There are four such jig pieces, the upper two can be identified by their shape. Attach the triangular “feet” provided and secure them to the building board over the plans. The forward jig goes over section C-C, the rear goes over section E-E. You should position the jig so that at least one outer wing panel can be fitted to the center section without moving the jig. It would be best if both panels can be fitted without moving the jig, but this may not be possible. In that case you will need to remove the center section (with jig) from the building board and turn it around so that you can fit the other outer wing panel.

2.3 Front Spar and Ribs

Start by fitting the front ribs to the forward carry-through spar. Use a square to align them as shown and then glue them in with CA. A good method is to use two passes of thin CA to tack them in place followed by a bead of thick CA. Thin CA alone is not very effective in bonding lite ply. Start with Ribs #1, then fit DB1, DB2 and Rib #2A and glue in place. Why is it rib 2A and not rib 2? Rib 2A is the only rib that is not in scale position! All the other ribs are shaped exactly like the original and are in scale position. Rib 2A had to be scaled somewhat.

Mind **carefully** the orientation of the ribs and spars. Check the plans if you have any doubts. It may be possible in some cases to glue things in upside down.

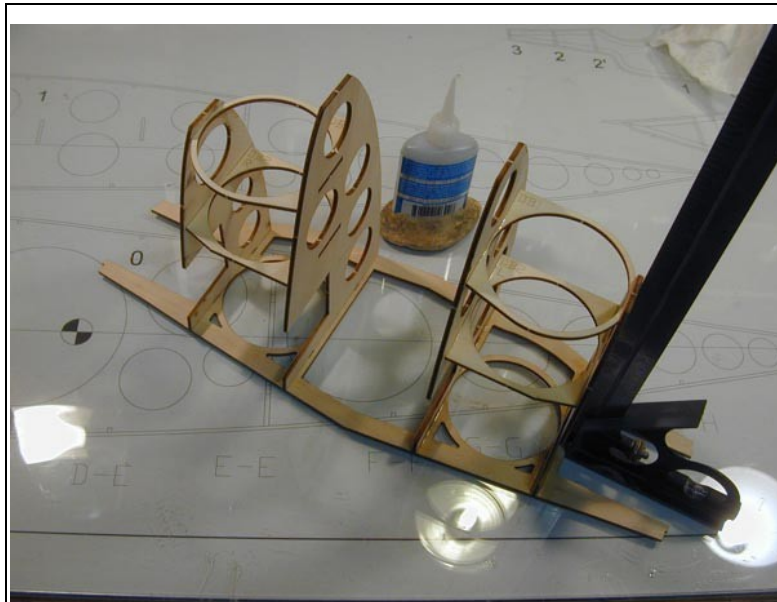

Figure 2: Fitting the forward ribs

Test fit the fan shrouds in place. They should align exactly with the openings in DB1, DB2 and the front carry-through spar.

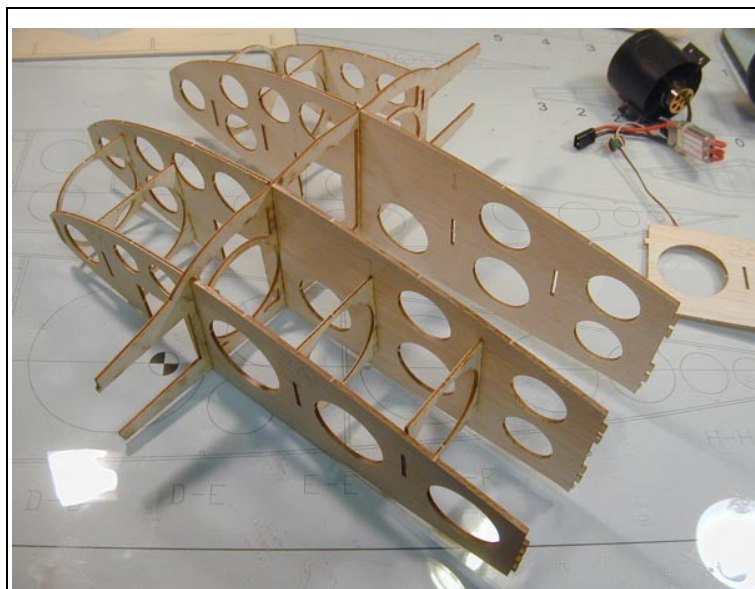

Figure 3: Installing the mid-section ribs

Install the mid-sections of ribs 1 and 2A as shown in Figure 3. Use a square to align rib 1 and glue in place. Fit DB3 & DB4 between ribs 1 & 2A, check alignment. Sight through the duct holes and make sure everything is aligned, then glue everything in place.

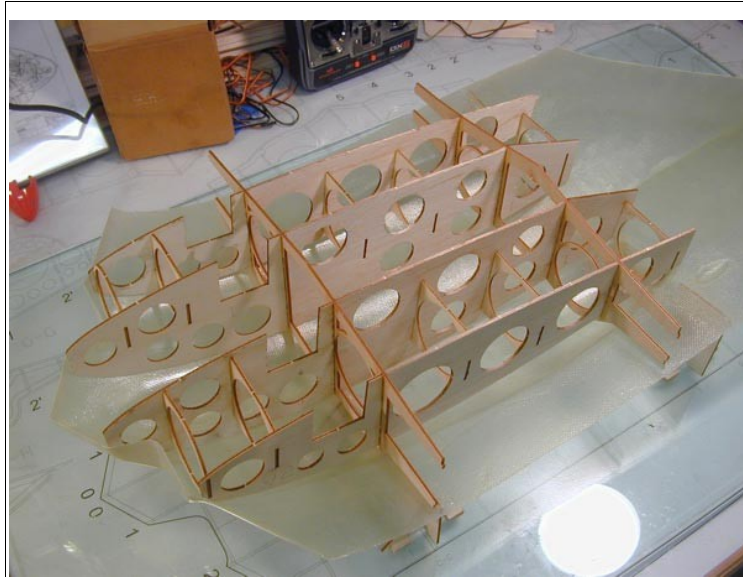

Figure 4: Basic framework completed

Now glue the rear carry-through spar to the rear of ribs 1 & 2A and attach the rear portions of ribs 1 and 2A to the spar. Attach DB5 by sliding it into the slots in ribs 1 & 2A. Check alignment and again sight through the duct holes. Glue everything in place. You can now set the framework into the fiberglass shell as shown in Figure 4. Check the fit, but don't glue anything yet.

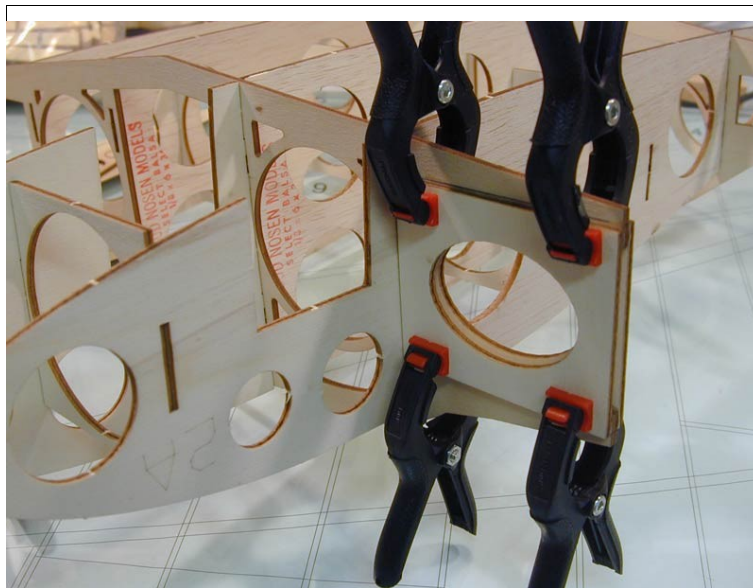

Figure 5: Forward spar braces

Next glue the spar braces to the spars as shown. Use epoxy and clamp the pieces in place. These form the slots for the wing joiner tongues. Clean out any excess epoxy before it sets and test fit the tongues.

Also at this time, cut some fan hold-down blocks out of spruce, ply or hardwood and epoxy them in place to ribs 1 & 2A as shown in Figure 6. We chose to use 1/4" spruce, with self-tapping screws to hold the fans in place.

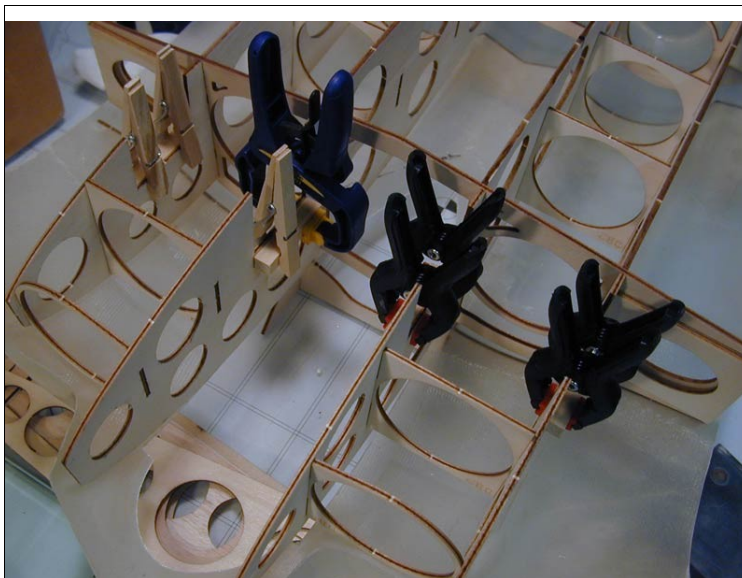

Figure 6: Fan hold-down blocks

Before going any further, assemble one of the fans and speed controller units and test fit them in place.

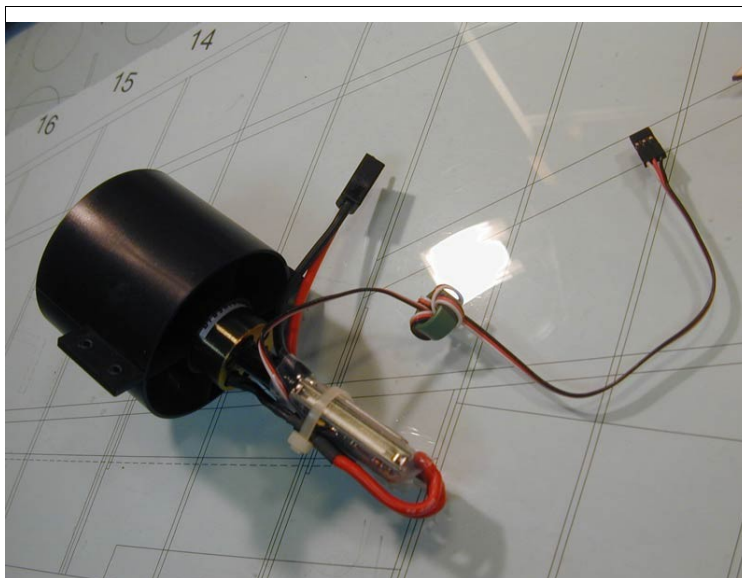

Figure 7: Fan and speed controller assembly

The speed controller and motor housing extend behind the shroud. It's important to keep this in mind when planning fan installation and access.

2.4 Intake Duct Installation

Figure 8 shows the intake duct installation. You can use a variety of materials for the intake duct. Just be sure whatever you use will bond well with the filler you plan to use around the joint with the fiberglass parts. You need to make a nice rounded lip on the intake to get efficient airflow into the duct.

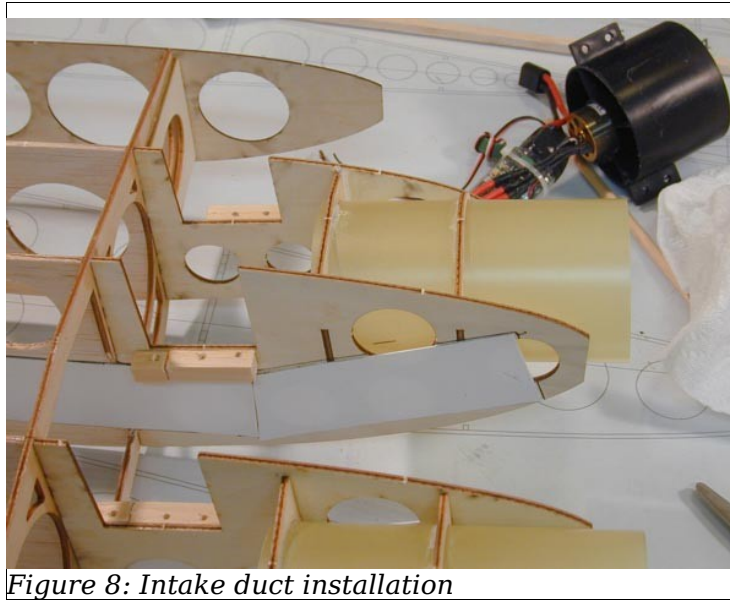

Figure 8: Intake duct installation

The material should also be strong enough not to collapse from the air pressure from the fan. Possible materials include sheet plastic, 1/64 ply or fliteskin. We've used fliteskin and epoxy/micro balloons with good results. A smooth, well rounded intake lip is important for efficient air flow into the duct. Keep in mind also that the front duct will tuck **inside** the front of the shroud unit. See the plans.

2.5 LiPo Battery Attachment

Ribs 1 can have velcro installed to hold the LiPo batteries. It is advisable to do this now while the access is easy. See Figure 9.

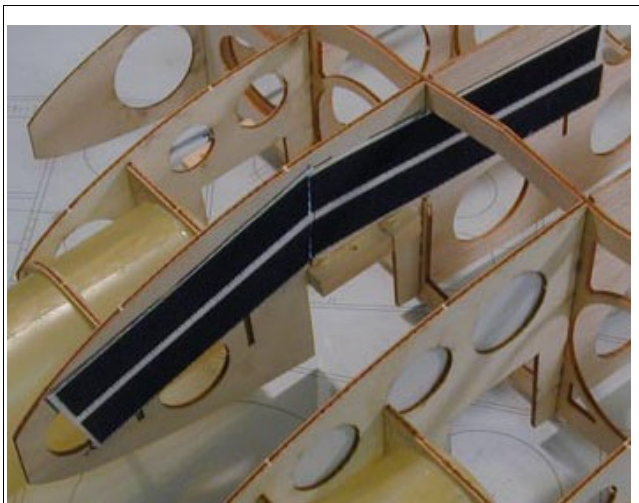

Figure 9: Velcro installation on Ribs 1

2.6 Installing Ribs 3A

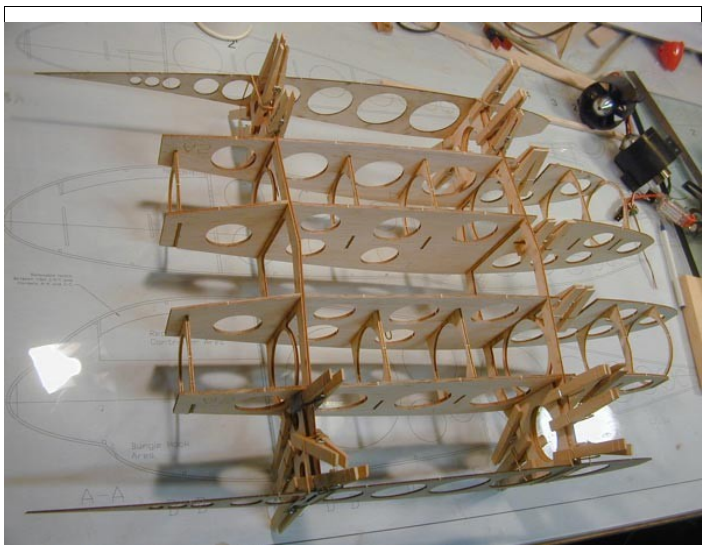

Figure 10: Ribs 3A installation

Ribs 3A should be bonded to the carry-through spars and their braces. You can use rubber bands to hold them in place while the epoxy sets. They should snap into place on the little tabs on the spars.

Check Ribs 3A with a straightedge, these should be straight and true. If they're not, you have an alignment problem with the center section framework. The aft

portion can be curved a little. You can straighten it later when the framework is attached to the upper shell.

2.7 Leading Edge Installation

Next we install the 1/4" x 1" balsa leading edges between ribs 2A and 3A as shown in Figure 11, which shows them sanded to shape. Also at this time, lay the upper shell on the framework and cut out the intake area. A dremel with a 1/4 router bit is a good tool for this. Mark the outline of the shell on the intake duct as shown. An optional laser cut leading edge is also provided for the nose area.

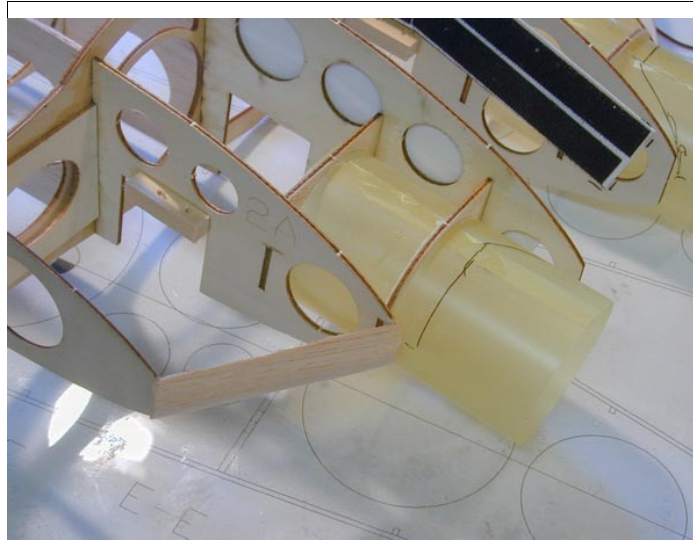

Figure 11: Leading edge installation

Also at this time, cut out the rear duct openings as shown in Figure 12. Use the scribed outline on the upper surface as a guide. You can also cut out the canopy.

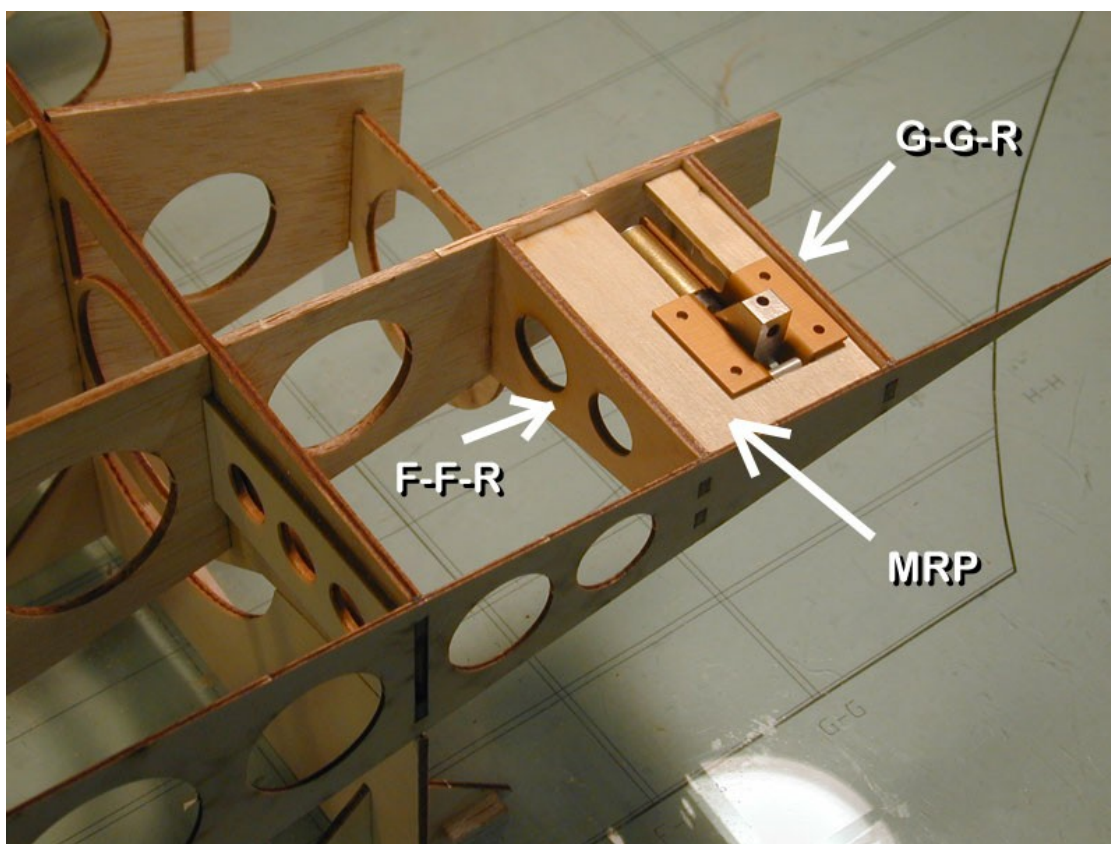

Figure 12: Rear duct openings

2.8 Retract Installation

Retracts have to be considered experimental in this model since they haven't been flight tested. Parts are provided, but we can only offer limited instruction since we currently have no experience with their application. Several people have begun working with retracts for this model, and updates will be posted to RCSCALEBUILDER.com and the Yahoo group as progress is made.

The main retract units are mounted to the Main Retract Plates (labeled MRP), these fit between ribs 2A and 3A as shown below. The retract formers F-F-R and G-G-R support the main retract plate. Mind orientation of F-F-R and G-G-R as these parts aren't symmetrical. The flatter part is on the bottom.



The MRP pieces are marked with a small crosshair to show the location of the scale strut. You may have to offset this slightly depending on the retract units chosen. We have chosen Spring Air retracts since they are lightweight, sturdy and relatively inexpensive. We're using the 603 units for the mains and the 706 unit for the nosegear. The nosegear retract plate (NRP) is sized to fit between ribs #1. See the plans for scale strut location. Both this and the main retract plates have to be cut out to fit the retract units of your choice. The NRP should be reinforced with triangle stock. You must also take into account the CG shift

when the nosegear retracts. Balance the model with the gear retracted.

2.9 Attaching the Framework to the Upper Shell

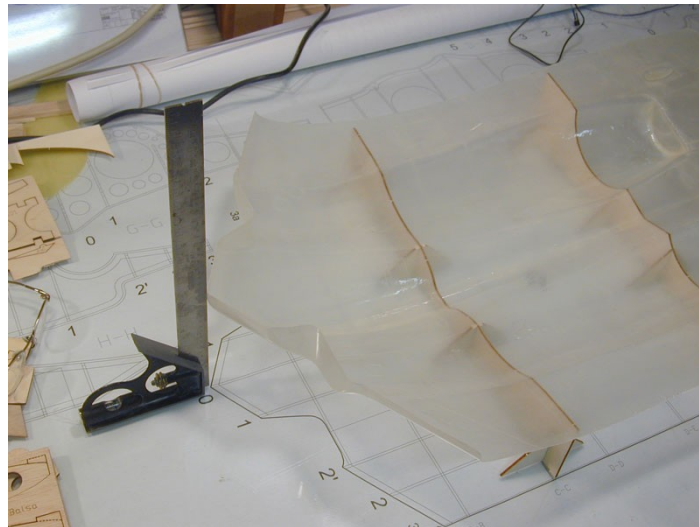

Figure 13: Positioning the upper shell

Start by placing the upper shell on the jig and aligning it with a square as shown in Figure 13. Lay the framework in place in the shell and mark the areas of contact between the framework and the shell. Remove the framework and rough up the areas to be glued with 150-200 grit sandpaper. Tack glue the shell to the jig with CA.



Figure 14: Applying filler to the intake area

Apply filler to the lip where it will contact the intake duct, and to the duct itself in this area. You want enough filler so that you can sand a rounded lip here.

If you're using West System epoxy, thicken it with Colloidal Silica powder and apply a bead to the shell where it will contact the framework and lay the framework in place. Weights can be used to hold it in place.

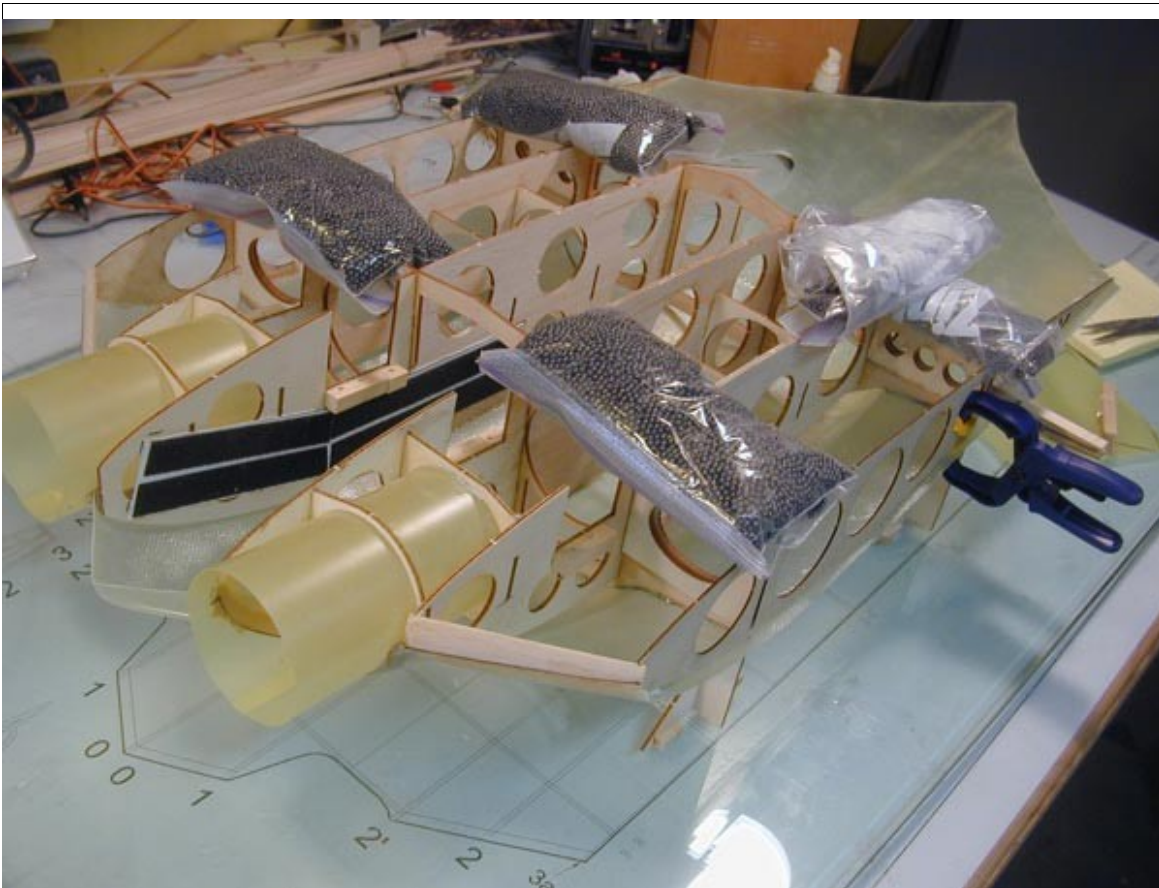

Figure 15: Attaching the upper shell

2.10 Fan Installation

With the center section still in its cradle (jig), test fit the fans and plan for access once the lower surface is sheeted. You will need to make hatches to access the fans and speed controllers. Plan your wiring layout. There are some excellent articles on <http://www.warbirds-rc.com> showing methods of EDF installation. I recommend you study some of those before attempting this if you've never done it before.

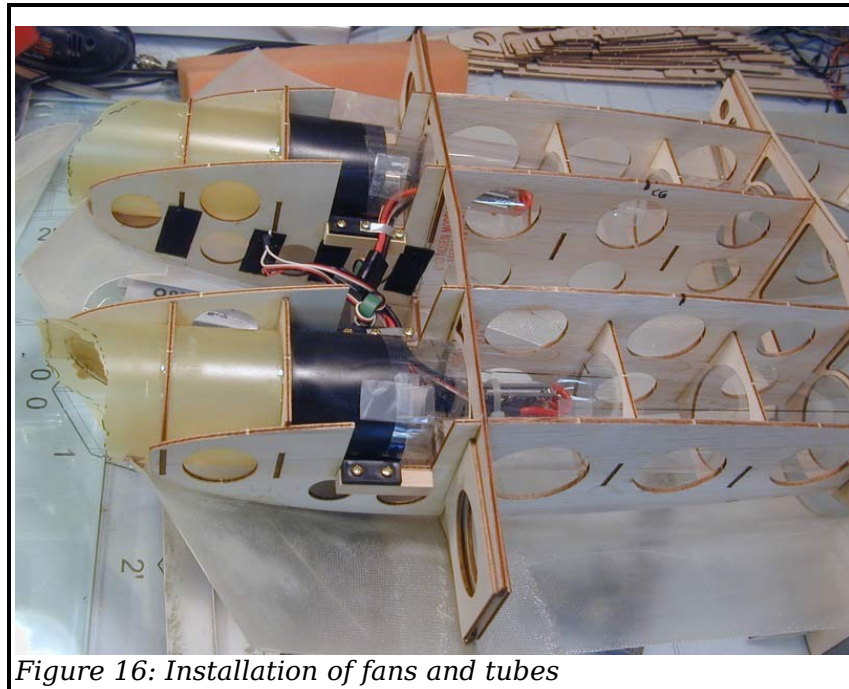

Figure 16: Installation of fans and tubes

Figure 16 and Figure 17 show the installation of fans and tubes in the prototype model. A sheet metal strap was used to secure the fan wires. Some straps made of tape folded over may be useful in positioning the rear duct.

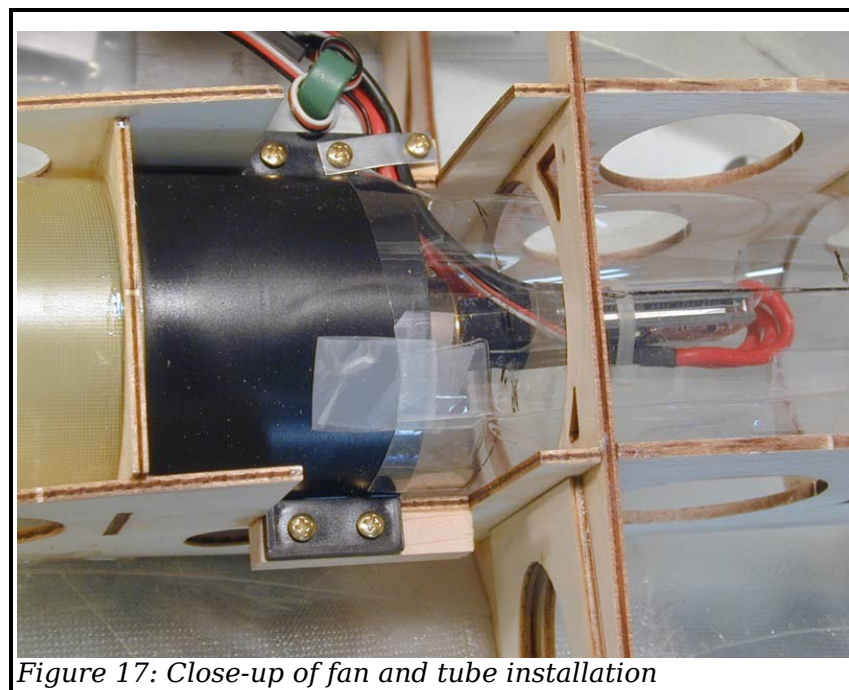

Figure 17: Close-up of fan and tube installation

2.11 Batteries

Plan the installation of your LiPo batteries. Unless you keep the structure aft of the CG extremely light, you will most likely end up with the batteries nearly all the way forward.

2.12 Connecting it all Together

Depending on the speed controller you choose, you will need to decide whether to use its BEC or not. Check the instructions that come with your speed controller. Depending on the motors and the current they draw from the main batteries, a BEC may or may not be appropriate. It is generally safer to run the receiver from a separate battery in a high power application, and that is what we've done with the prototype model. To do this, just cut the positive (red) lead from the speed controller to the receiver and connect a receiver battery to the receiver in the conventional way.

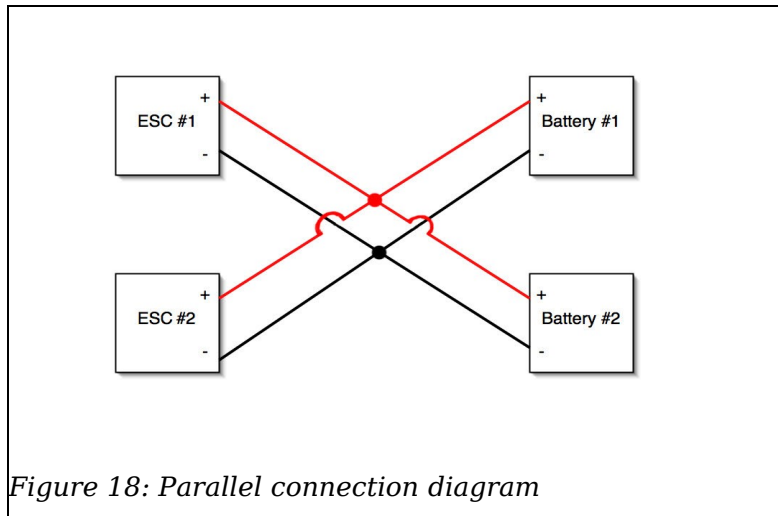

2.12.1 Battery Connection

There are two ways to connect the batteries to the speed controller. Each battery can be connected to each speed controller independently. Some prefer this kind of installation since faults will be isolated to one side or the other. However, any differences in current from the batteries will cause an imbalance in power output from the fans. For this reason many prefer a parallel connection. This way both speed controllers always see the same current from the batteries. This is the method we chose for the prototype model and it has worked well.

A diagram showing parallel connection between the ESCs and Batteries is shown in Figure 18 below. It is actually very simple, just connect all of the positive (red) wires together and all of the negative (black) wires together. It's up to you how and where to put connectors. It is usually convenient to be able to separately connect each battery and ESC, which is why the parallel adapter shown has connectors at both ends.

A photo of this installation in the finished prototype model is shown in Figure 19.

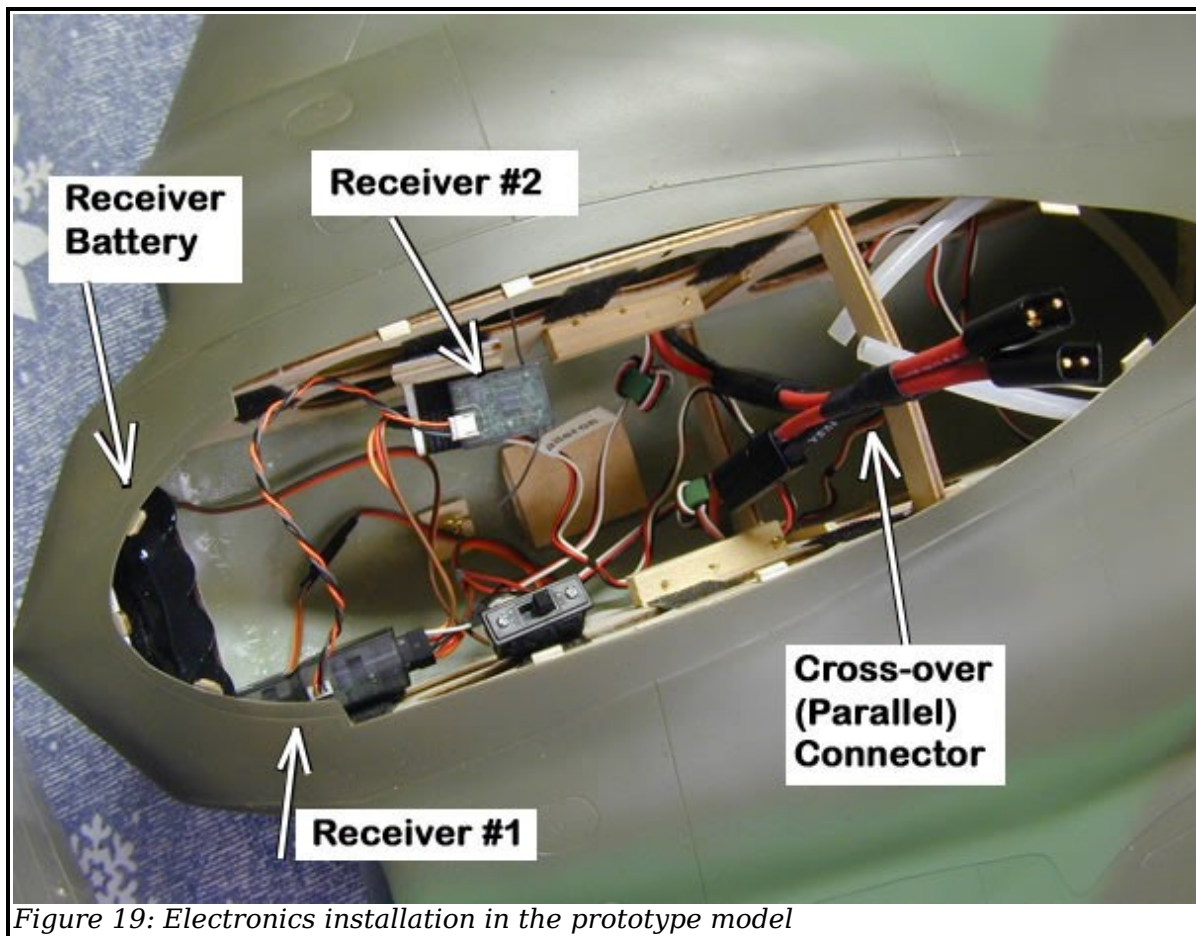

2.13 Rear Duct

See the plans. There is a template on the plans for cutting out the rear duct. Cut out the duct, roll it up and insert it through the duct brackets. Let it expand and use a few pieces of tape to hold its size. Remove it and use clear packing tape to permanently tape it together.

The warbirds-rc articles show how to make and install a rear duct. See

<http://www.warbirds-rc.com>. Because ours will be rather long, you'll need to devise a method for installing it from the rear. It would be best to do that now while you have easy access to everything. We found that a piece of doweling 22" long or so makes this job easier. Use the dowel to collapse the clear plastic rear duct tube after it is taped together. This makes it small enough to fit through the duct brackets easily. Fitting the duct around the speed controller and mating it to the fan shroud is a bit tricky. It gets easier with some practice.

Once you've installed all interior equipment and planned for all necessary access, we can move on to sheeting the lower surfaces.

2.14 Rear Duct Fairing

The rear duct is not permanently installed. It will be rolled/folded and slipped into the brackets and secured to the fan shroud with tape. You need a fairing for the aft portion though, the part that cuts into the wing. We chose fliteskin for this fairing, but it can also be made from 1/64 ply or sheet plastic. Figure 20 shows the fairing attached to DB5 and the fiberglass shell. A fillet of epoxy and micro balloons is used to allow some sanding of the joint without breaking the fairing loose.



Figure 20: Rear duct fairing and filler application

3 Outer Wing Panels

3.1 Laminating the Rib Doublers

Start by laminating the ply doublers onto ribs 3B, 4 and 5 with epoxy.

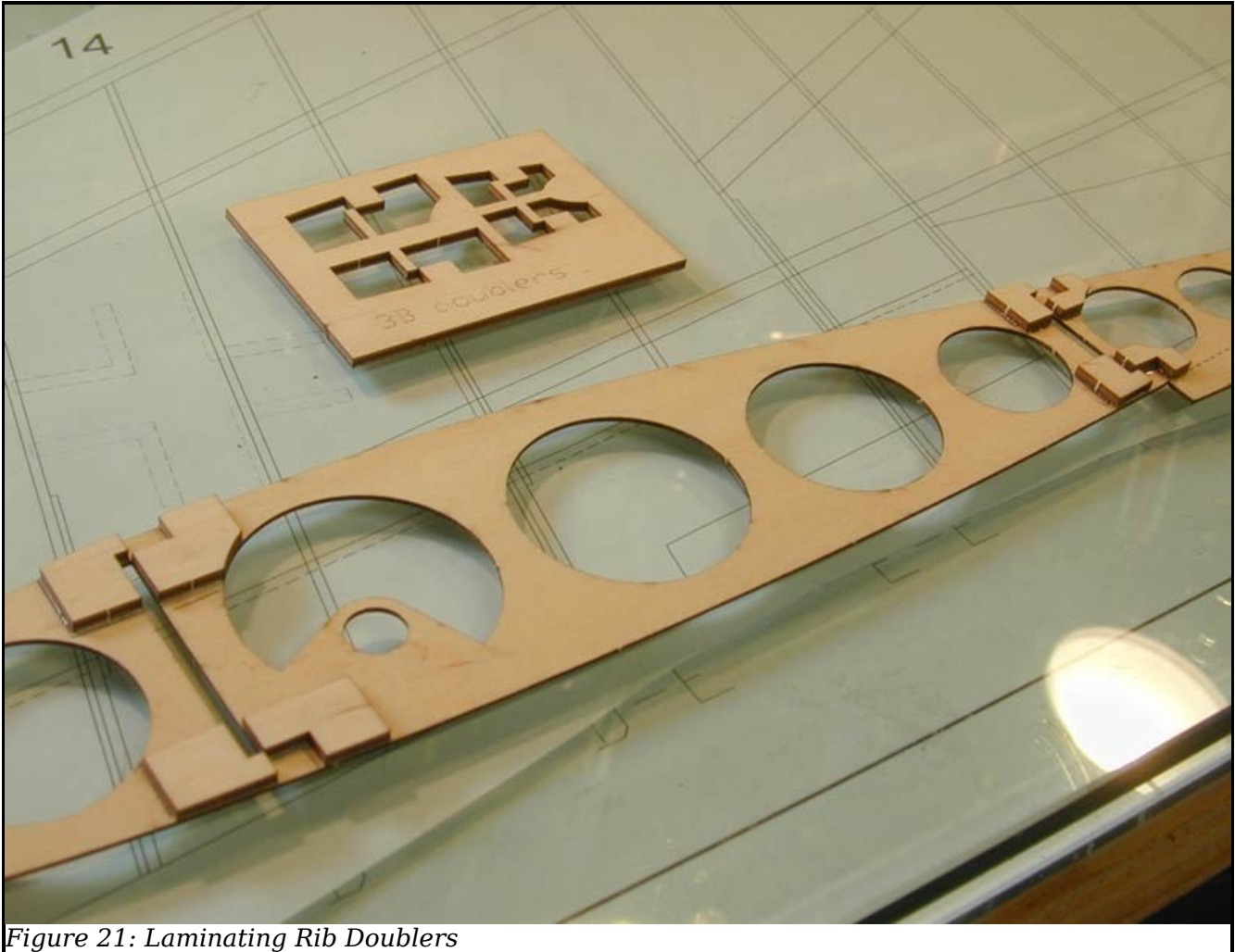

Figure 21: Laminating Rib Doublers

It helps to mark the doublers before removing them from the parts sheet so their location and orientation can be determined.

These glue ups should be done with epoxy since this is a high stress area. Be sure and make a right hand and left hand set for ribs 3B, 4 & 5. The doublers go in the **outboard** side for ribs 3B and 4, and on the **inboard** side for rib 5. See the plans.

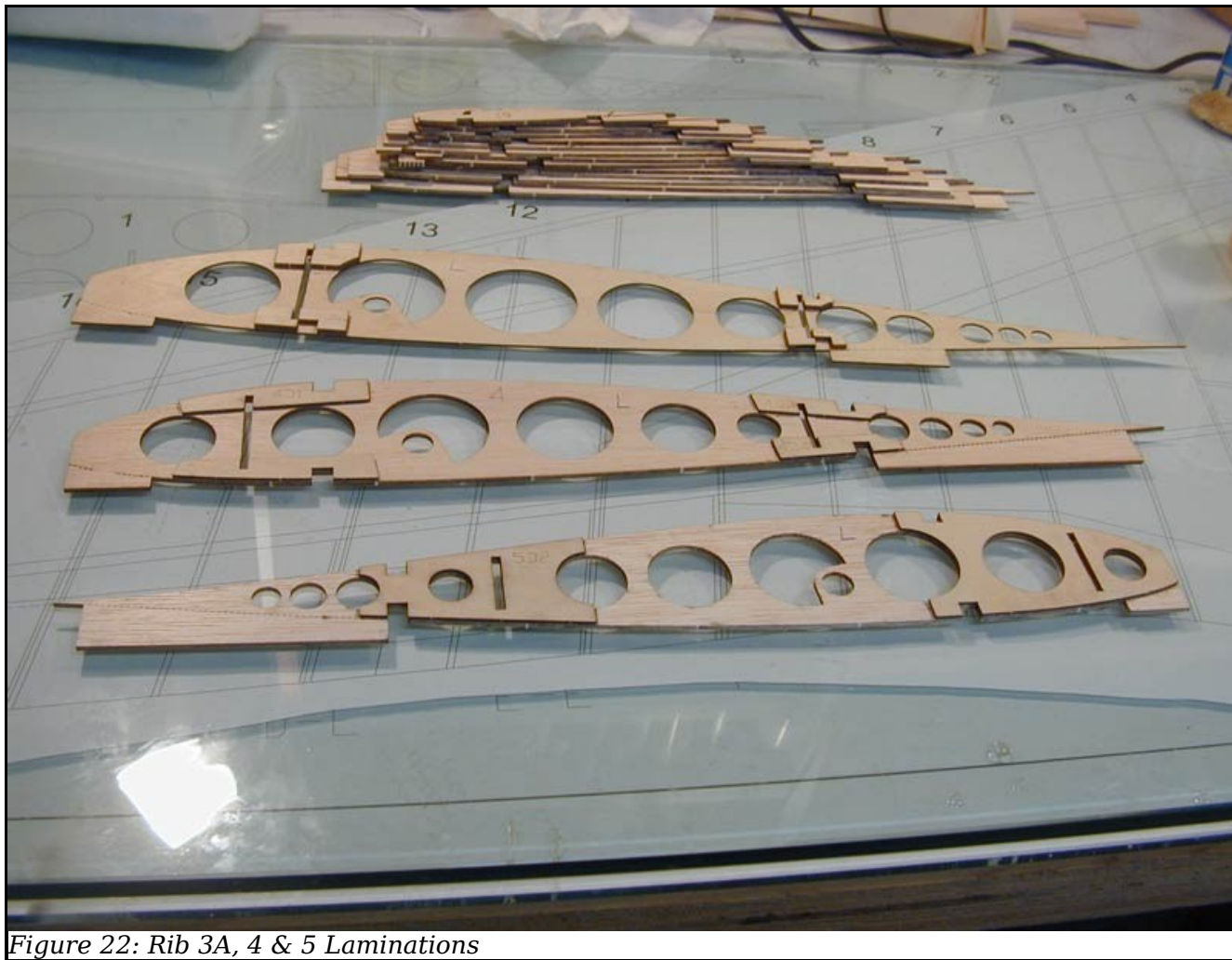

Figure 22: Rib 3A, 4 & 5 Laminations

3.2 Laying Down the Ribs

The ribs are at an angle to the building board. This is so the ribs will end up square to the wing datum line which makes everything easier later. Just use one of the supplied jigs (inside (inboard) or outside (outboard) - whichever you prefer) and attach the ribs to the building board using the “feet”. See Figure 23. Make sure to align ribs 3A, 4 & 5 **carefully** so that the slots for the spar tongues are in a straight line. Sight down from the top to align these over the plans. Use a scrap piece of 1/8 ply to ensure this alignment before going any further.

The ribs should lean outward toward the wing tips. You can glue some 1/8” or 3/16” square stick scraps to the feet to make pinning them to the building board easier. They’ll be less prone to splitting also. Pin down the ribs from the root out to rib #11 and then install the elevon conduit (optional) before pinning down the remaining ribs. There are enough holes in the ribs that feeding a servo wire

through shouldn't be a problem, but if you want a sure fire path then install a conduit. The prototype in the photos was built on a glass sheet over the plans, which is why you don't see any pins.

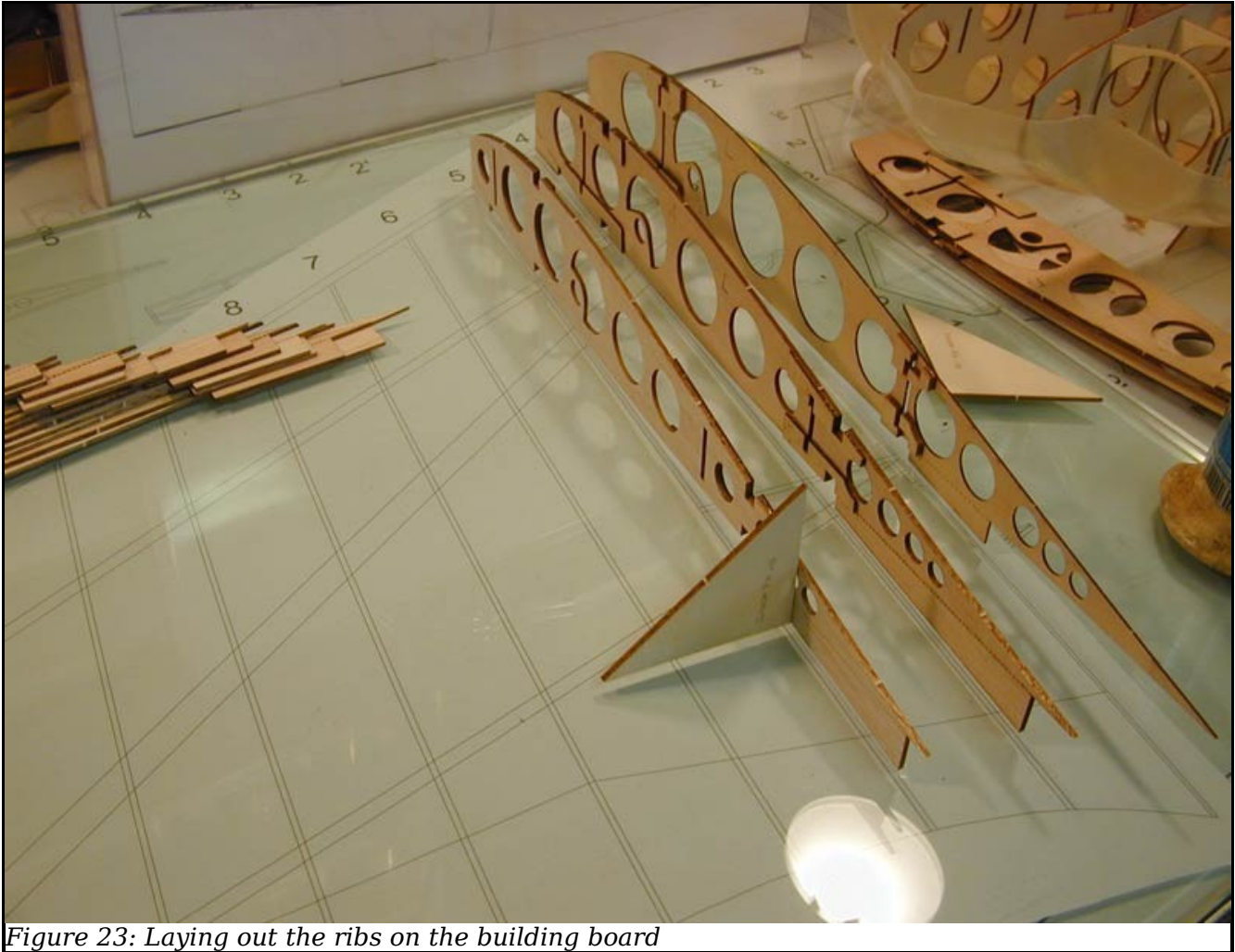

Figure 23: Laying out the ribs on the building board

3.2.1 Elevon Servo Conduit

Install the conduit into the holes cut into the ribs. Rolled butcher paper or old plans make an excellent conduit. This conduit just makes fishing the elevon servo leads through the wing easier. They aren't absolutely necessary. Now pin down the remaining ribs.

3.3 Installing the Laminated Spars

The upper spars have significant curvature, so they are laminated from two pieces of 1/8" x 1/4" balsa. Start with the front spar. Note that the first (bottom) piece extends only to rib #18. Also mind the alignment of rib #3A. It is very important that rib #3A be straight and true, as this is the mating surface with the center section. Check its alignment frequently with the rib jig and a straightedge fore to aft.

Lay the first piece of the front spar into the notches and tack it in place. This piece will fix the alignment of rib #3A, so install it carefully. The spars are curved near the root, so make sure you glue them down all the way into the notches. The second piece extends all the way to the wing tip. Lay a bead of thick CA on the first piece and glue the second piece down.

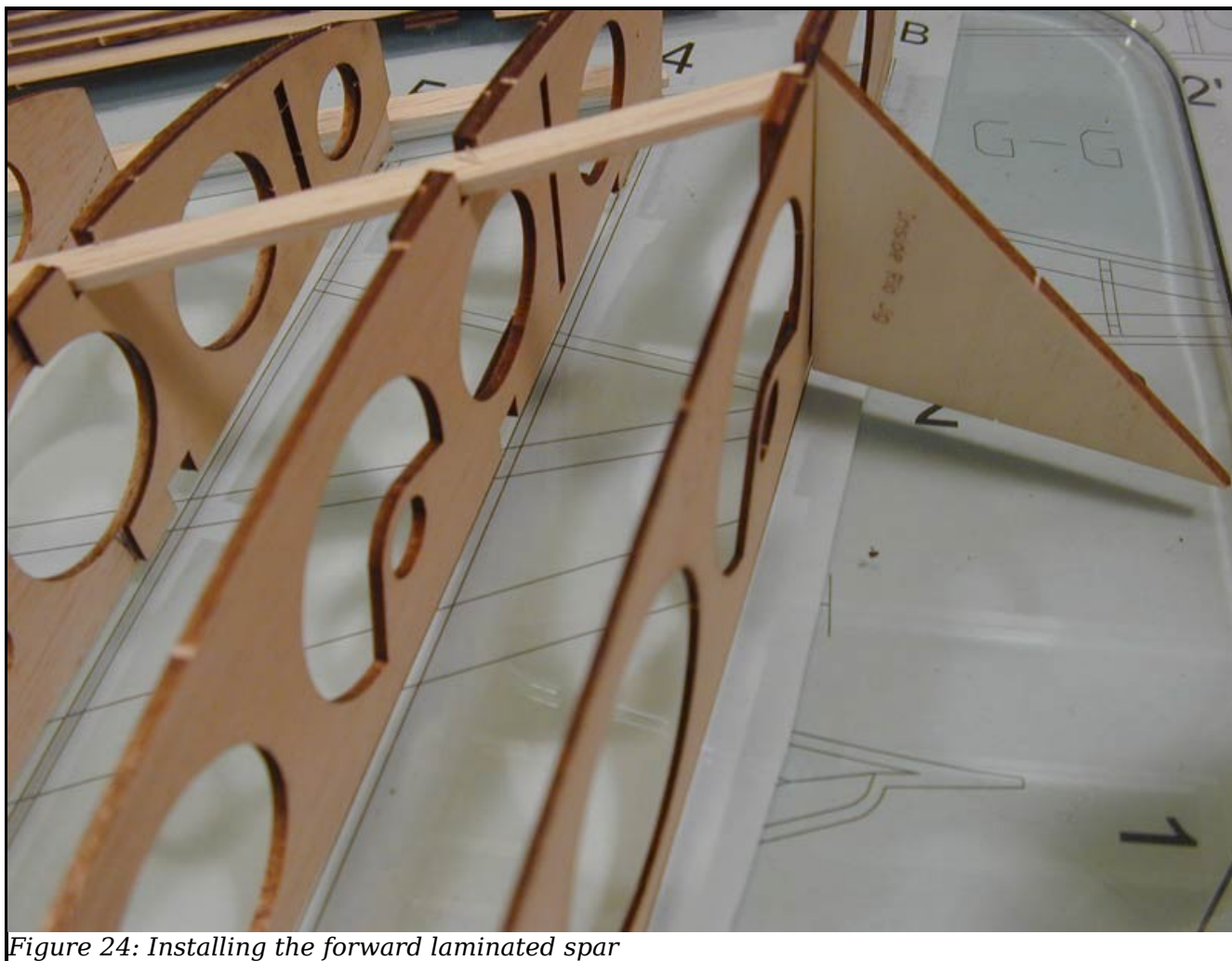

Figure 24: Installing the forward laminated spar



Figure 25: Installing the rear laminated spar

Repeat for the rear spar. Note that the bottom piece of the rear spar only goes from rib #3A to rib #7. See Figure 25.



Figure 26: Leading edge installation

3.4 Leading Edge & Sheeting

Install the 1/4" x 3/4" leading edge. The LE tapers significantly, so you will need to laminate some extra 1/4" pieces on the root side. Just make sure you have it thick enough to reach the edges of the ribs all along the top. There is a spliced piece at the wingtip, bevel it using the plans for reference. The LE is curved, but don't bend the balsa LE as you may induce a warp. Just let it follow its natural shape and laminate extra pieces as necessary to cover the front of the ribs. See Figure 26 and Figure 27.

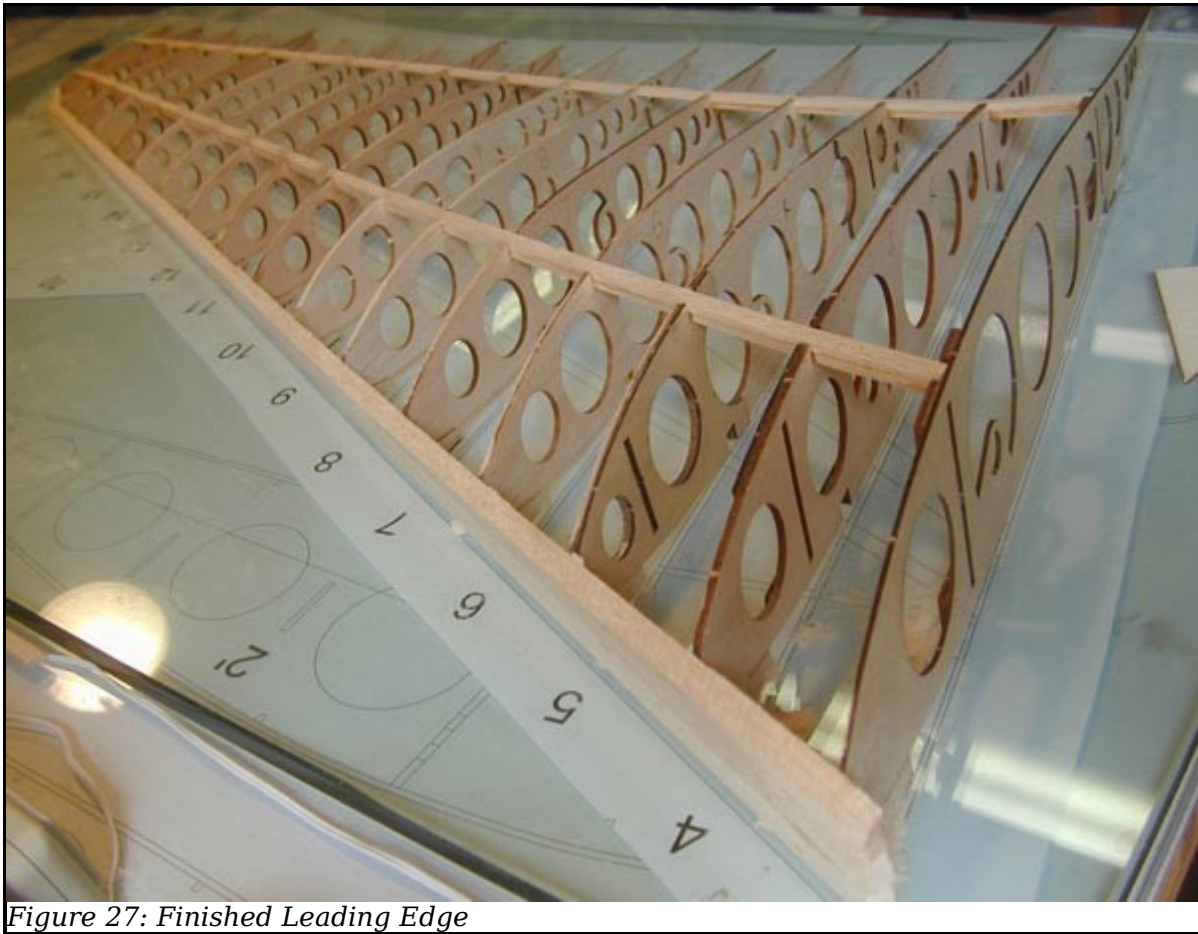

Figure 27: Finished Leading Edge

Bevel and sand to the LE to match the rib contour. A mouse sander works great for this. Give the entire upper wing a light sanding. Sheet the top of the panel using 1/16" balsa and your preferred method. The curvature of the upper surface makes the sheeting job a bit tricky. Take your time, it may help to sheet it in sections, for example, sheet the area between the two spars first. If you plan to install flaps, glue in the upper flap sub-spar as shown in Figure 28.



Figure 28: Flap sub-spar installation

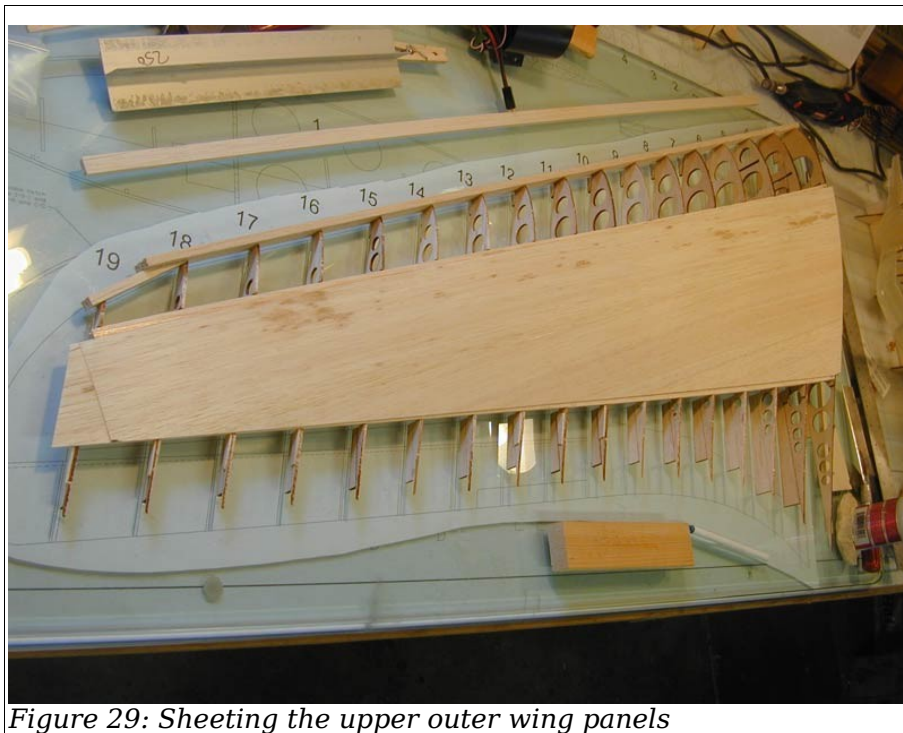

Figure 29: Sheeting the upper outer wing panels

If you're using 36" sheeting, you will have to splice some extra sheeting at the wingtip as shown in the illustration as 36" sheeting is not quite long enough.

You can use 48" sheeting to avoid this, but you'll end up wasting a lot of wood. The rear spar will need to be shaped between ribs 18 & 19. Sand it down even with the ribs.

Make sure you get good contact between the ribs and sheeting **everywhere**. The shape of the wing near the root contains compound curves. The shape is actually concave at the root of the upper surface near the TE. This is because of the reflex in the airfoil and is very important.

Also make sure you have enough sheeting overlapping the trailing edges of the ribs by at least 3/4". You will trim back the TE later to 1/2" past the rear tip of the ribs.

When the glue is dry, remove the wing from the building board and flip it over. It should look something like Figure 30. Trim the "feet" from the ribs. The feet are perforated, so you may be able to gently break them free, but it is advisable to at least score through one side with a hobby knife first to make sure it breaks cleanly.

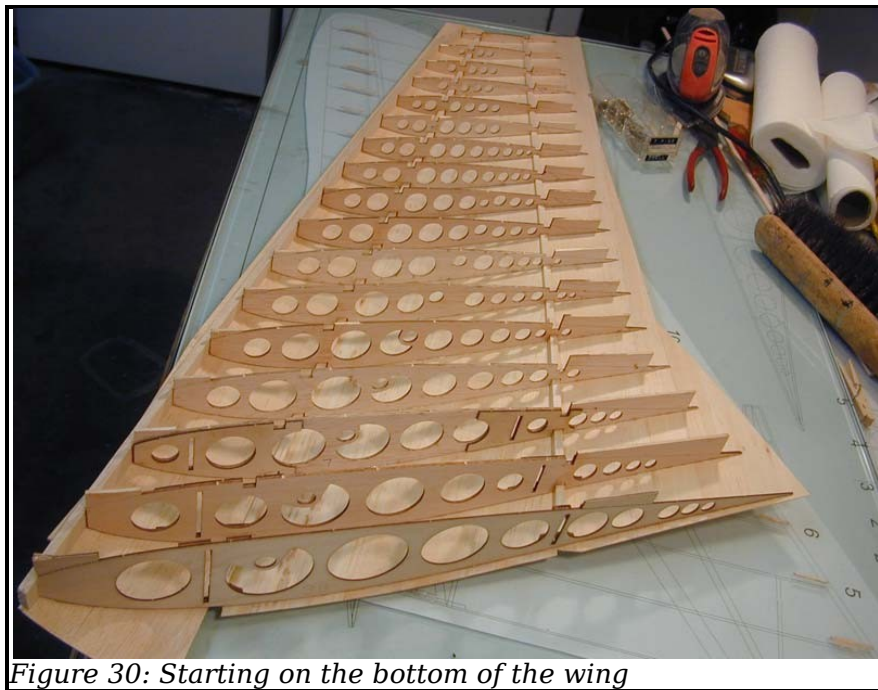

Figure 30: Starting on the bottom of the wing

4 Completing the Outer Wing Panels

4.1 Fitting the outer wing panels

Trim the fiberglass shell at the root rib and sand smooth. Slide the outer wing panels by the spars through the slots in ribs 3B, 4 & 5. Make sure that you have a good fit and that the mating surfaces at 3A & 3B fit well. Sand/shim until you achieve a good fit. Don't glue them yet!

4.2 Determining Attachment Method

At this point you need to decide how to attach the outer wing panels. They can be glued permanently or be made removable. If you're going to glue them on, don't do it yet! If you want them removable you have to provide a means for holding them in place in flight. There are many ways to do this. One good way is to use plywood shear webs for the outer wing panels on the front and rear spars between ribs 3B and rib 4. These parts are supplied with the laser cut kit (parts #WJ1 & WJ2). A hardwood block can be shaped and glued to the shear web to make a face for the screw. A block of scrap plywood can be attached to the inside of rib 3A and the spar braces. We recommend glassing this area to bond the block firmly to the spars. Without reinforcement we have found this are to be weak and break loose. Drill a pilot hole through both blocks with the wing panels in place. Drill a clearance hole in the outer wing panel part and make an access tube to extend through the skin. Some plastic tubing can be used to make screw access holes. Sand them flush with the ribs. See Figure 31 and Figure 32.

If you choose this method, it is best to have the screws “pull” at the middle of the wing and not just at the bottom. The first prototype had blocks and screws near the bottom surface of the wing. Concentrating the strain there caused the root ribs to crack away from the outer wing. The binding force should be delivered to the spars, top and bottom evenly.

Once you've solved the attachment problem we can go on to installing interior equipment and sheeting the lower surfaces.

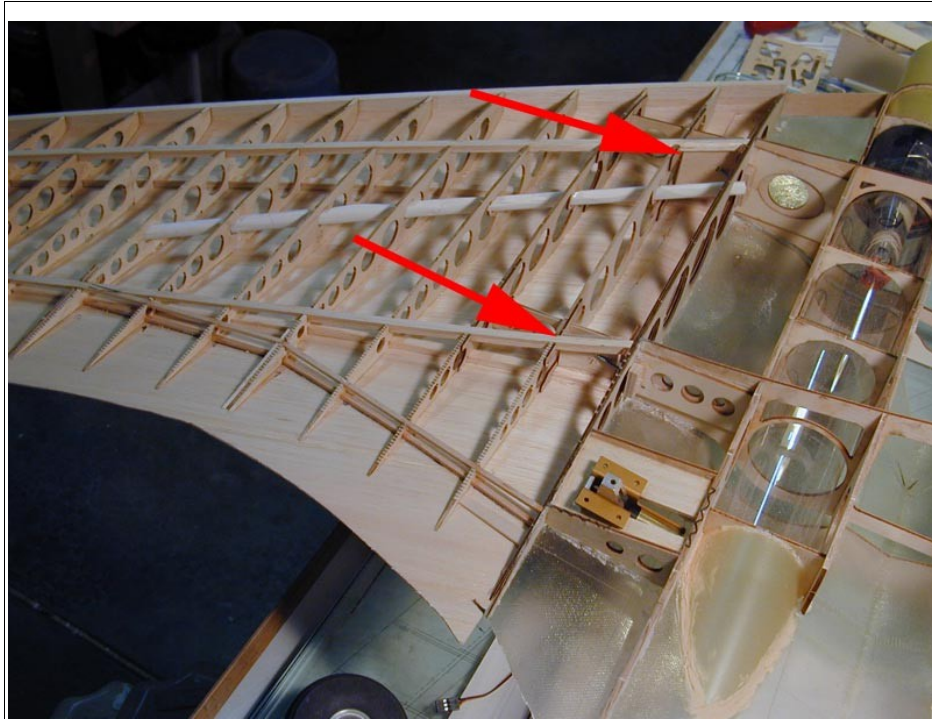

Figure 31: Outer wing attachment method

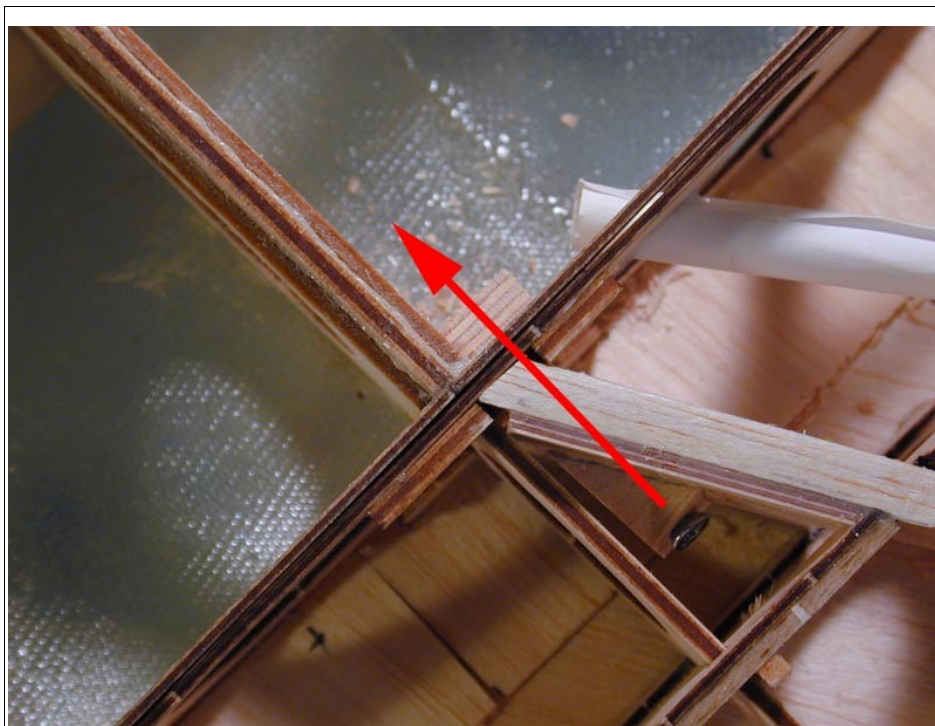

Figure 32: Ply shear web and screw blocks

4.3 Jigging the Outer Wing Panels

Separate the outer wing panel(s) from the center section. After sheeting the bottom of everything you can finish fitting them to the center section. You will now be using the opposite wing plan to fix the “wash” (twist) of the wing while attaching the lower spars and sheeting the bottom. At the lower left of LP02 (lite ply parts sheet #2) are five jig pieces sized to fit the sheeted top surface of the outer wing panels. These pieces will be used for both outer wing panels. Attach them to the building board over their respective rib outlines. They should be marked by the laser, but if the markings aren't clear, match them up to the ribs on the plans. They should go on ribs 3, 7, 11, 15 & 19. Use the rib jig to attach these at the same angle as you did the ribs earlier. Once again some “feet” made of scrap balsa may be helpful in pinning these down. Test fit the wing in place as you build the jig. See Figure 33.

If properly constructed, this jig will allow you to build in the correct one degree of washout.

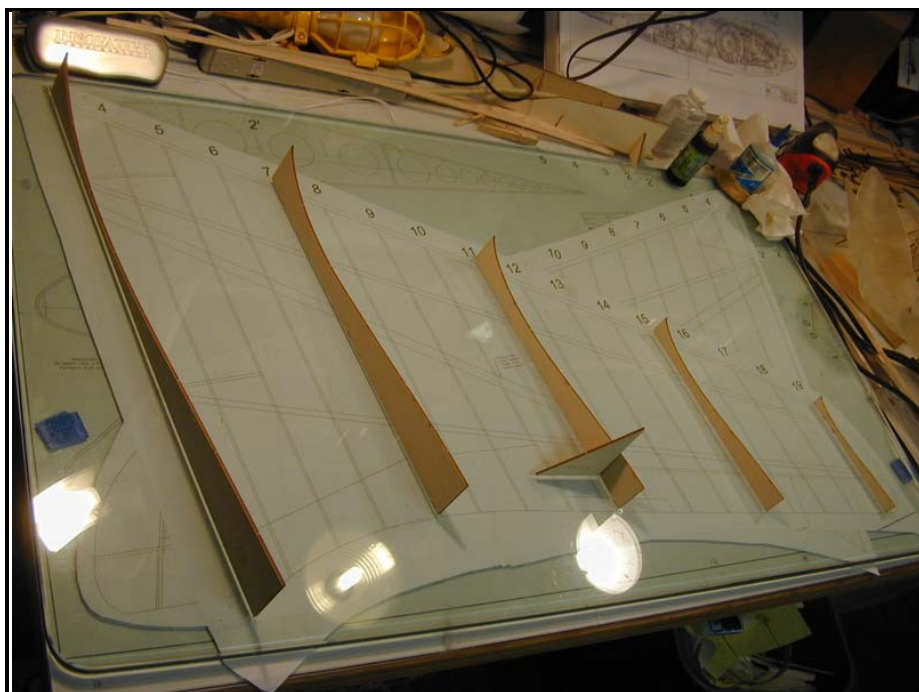

Figure 33: Attaching the wing jig to the building board

If you plan to install drag rudders, cut out the opening in the sheeting for the upper drag rudder now. It's easier to do this before the lower sheeting is in place.

Now place the wing upside down in the jig. Align the root and tip ribs with the jig and secure it in place. See Figure 34.

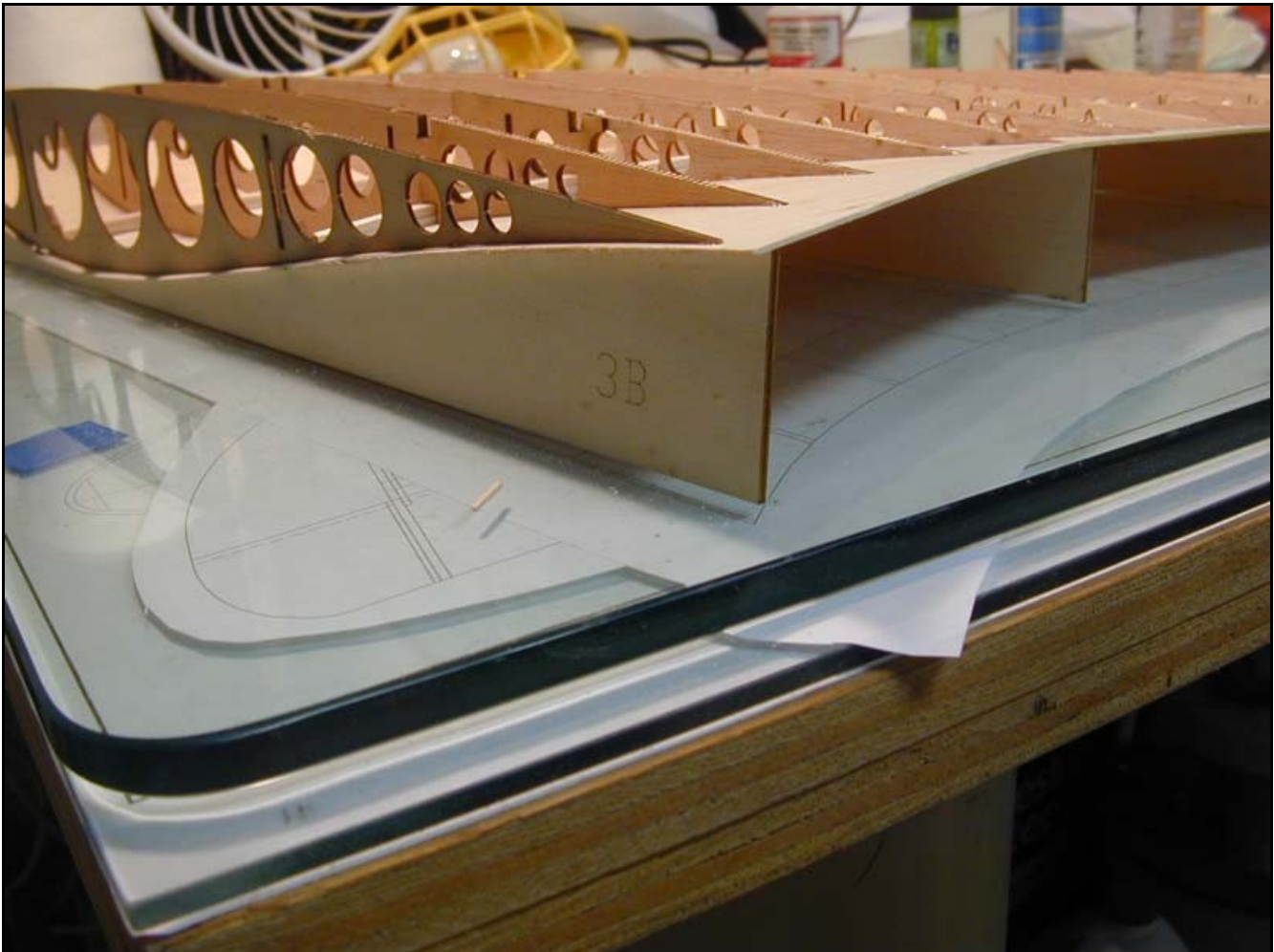

Figure 34: Attaching the wing to the wing jig

Now shape the bottom of the LE to match the rib contour. Install the lower laminated spars in the same way you did the upper spars. Sand the trailing edge to match the rib contour. You should end up with a sharp trailing edge. A mouse sander is a good tool for this.

4.4 Elevon Servo Installation

There are many ways to install servos in a wing. Rails and a mounting plate are provided from lite ply. It is recommended that you install the elevon servo between ribs 10 & 12. There is a horn built into the hinge on rib #11, so you should plan your pushrod installation accordingly.

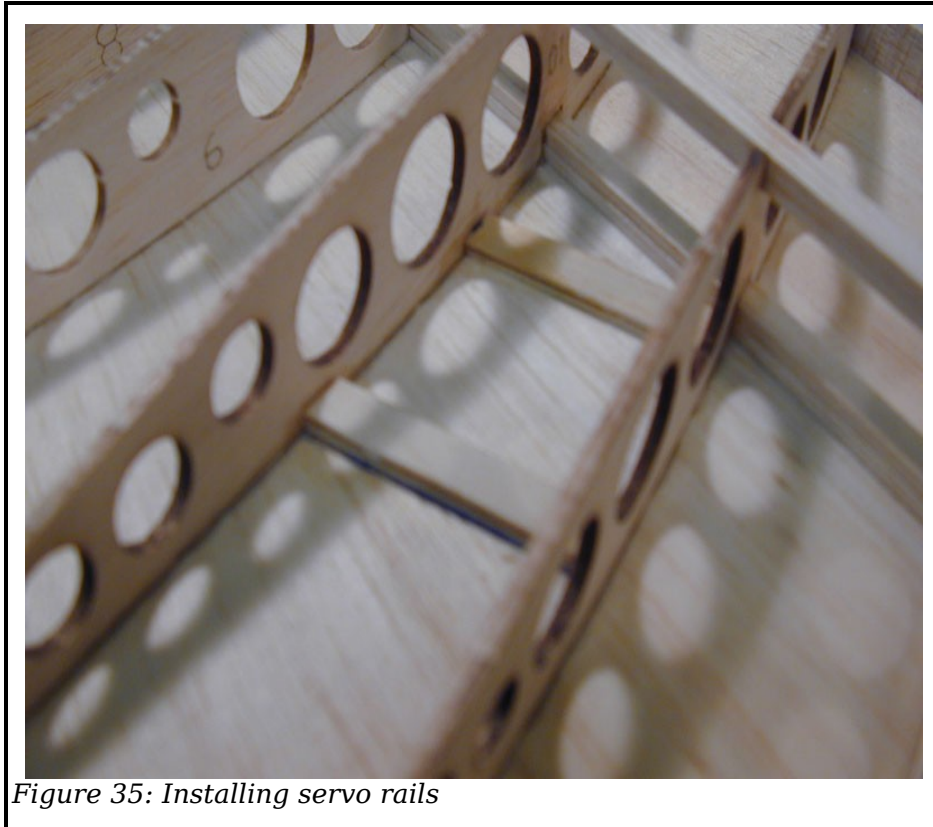

Figure 35 Shows the servo rails installed in the first prototype between ribs 10 and 11. A standard servo will just barely fit in this space. The plans now show an installation across two rib bays, #10 - #12. The single bay installation was too cramped. Using two bays will make servo installation and access much easier. See the plans.



Figure 36: Servo tray installation

Figure 36 shows one possible servo tray with spruce rails for servo mounting. You can also just attach the servo to the tray using double-stick tape or glue.

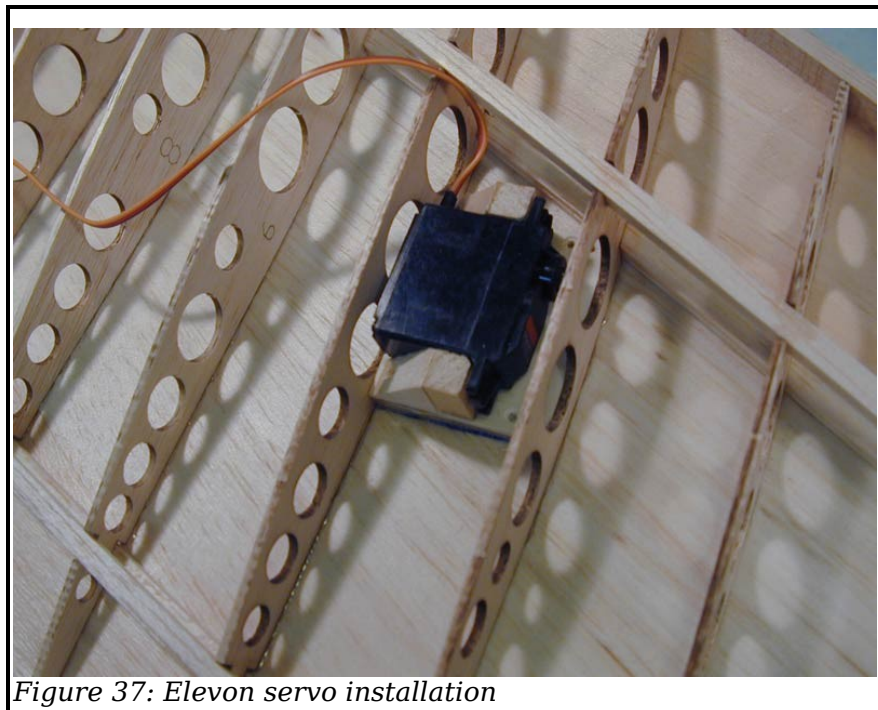

Figure 37: Elevon servo installation

The servo is shown in place in Figure 37. The pushrod should be attached on the bottom and lead upward to exit the top sheeting near the horn on rib #11.

When you are satisfied with the elevon servo installation, you can sheet the lower wing. You will have to cut an access hatch later.

4.5 Drag Rudder Construction (optional)

The following shows the construction of scale drag rudders. These look good and are very effective, but they are also difficult and time consuming to build and set up. A simpler version is possible by simply hinging them at the skin line much like spoilers on a glider. We are told these are just as effective, but they haven't been prototyped on this model.

Start by laminating the drag rudder framework pieces with carbon fiber veil and thin CA. Make a torque rod from doweling or carbon fiber rod (recommended). Start with the upper drag rudder. Glue the arms (3) to the torque rod using epoxy. There are two arms for the rudder itself and a third small one (not shown in the picture below) for the pushrod. Make the upper drag rudder in the same way.

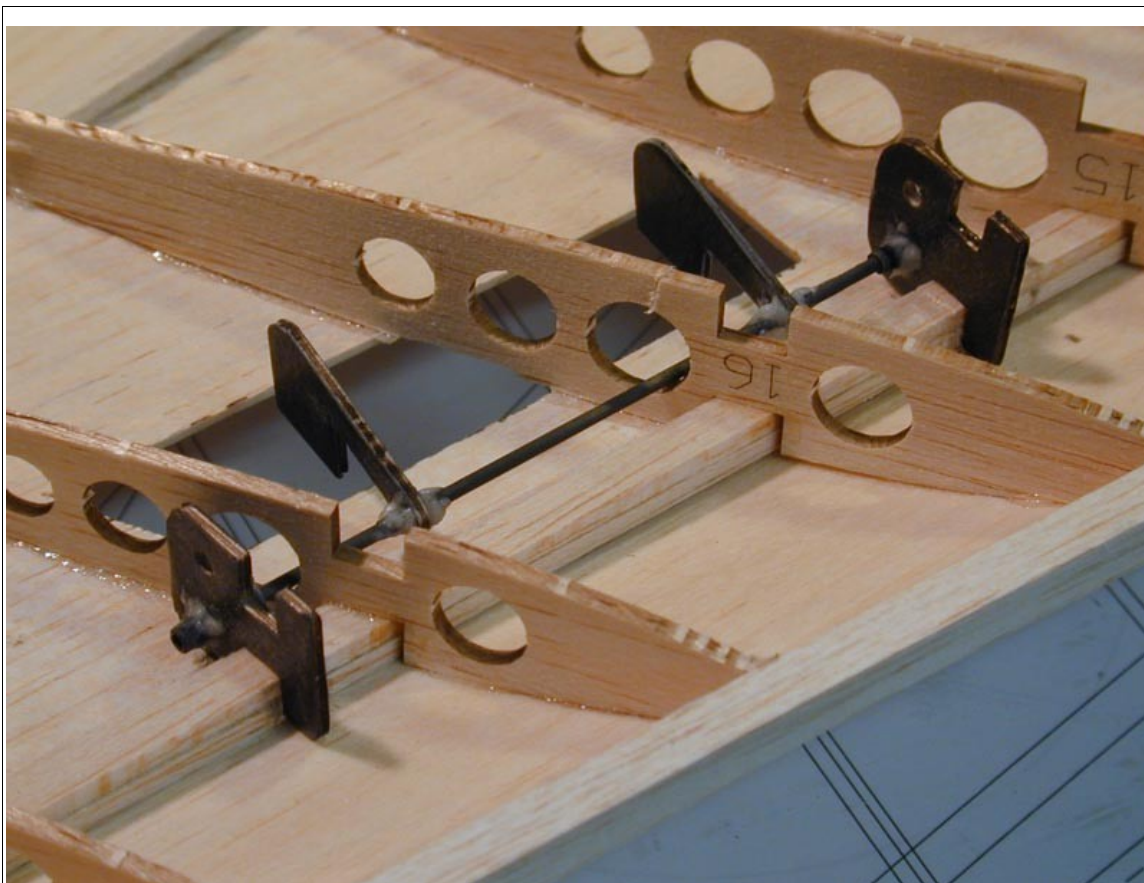

Figure 38: Drag rudder framework

Plan the servo installation. Micro servos will fit between the spars and the leading edge. The push rod should be perpendicular to the torque rods.

The torque rods should be fixed in place somehow so they don't slip sideways. We filed a groove into the torque rod and used small metal clips to hold it. See Figure 39.



Figure 39: Torque rod clips

Now fit and glue the baffle between the two arms as shown in Figure 40. Also shown in are stop blocks. These are made from soft balsa and are necessary to keep the drag rudders closed. As we'll see, a rubber band or spring keeps them closed, the pushrod pushes them open.

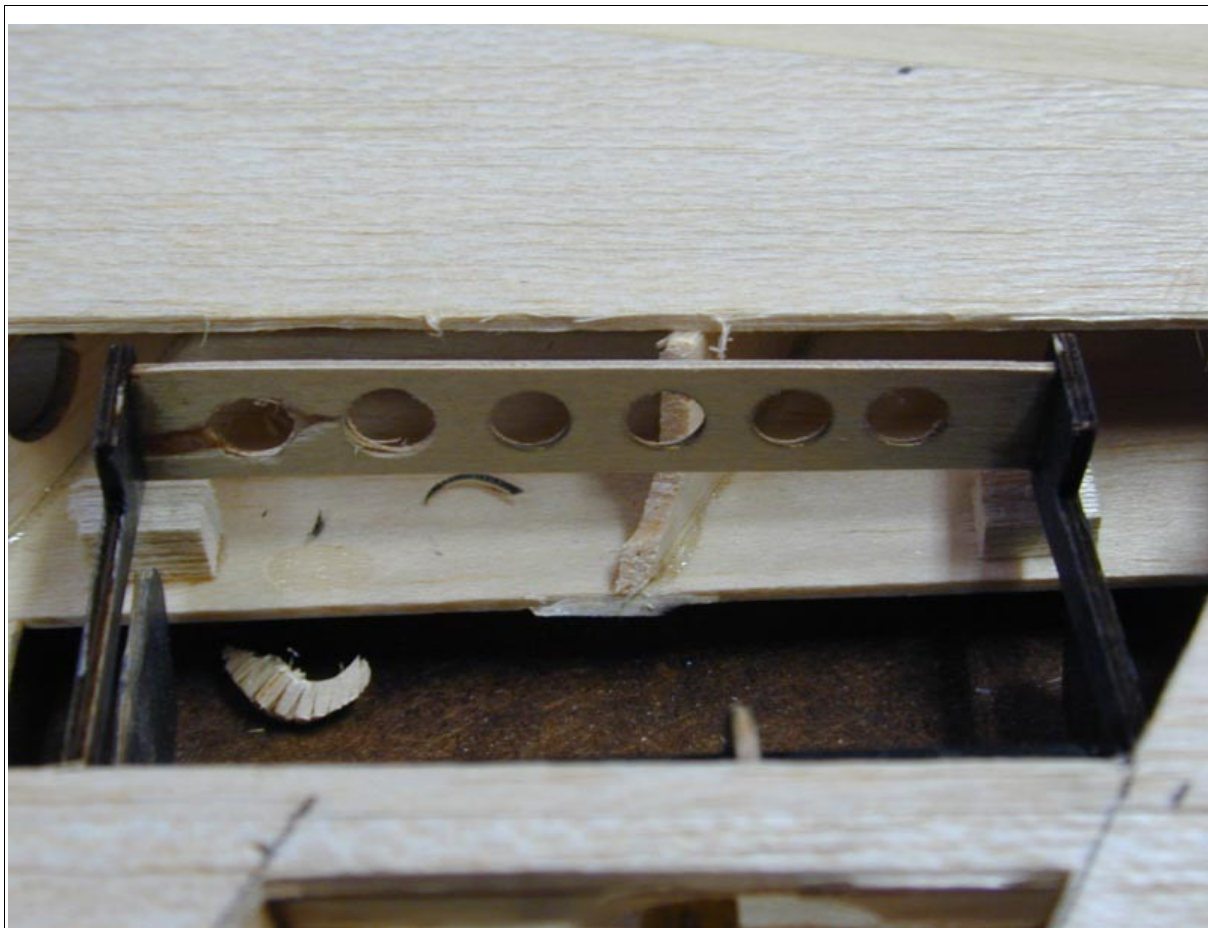

Figure 40: Drag rudder baffle and stop blocks

Check the movement of the drag rudders. Make sure they clear each other and there is no rubbing or binding. Make the pushrods as shown on the plans. Cut two 1/8" dowel pieces 3/4" long. Drill 1/32" holes in each end as shown. On the servo side, the push rod will slide in and out of this hole. This allows you to use a standard servo setup as for ailerons. Only the "push" side will cause the drag rudder on one side to deploy. The "pull" side will do nothing since the pushrod will just slide partway out of the hole. You can use springs or rubber bands to pull the drag rudders closed. We chose to use rubber bands stretched around the pushrods as shown in Figure 41.



Figure 41: Completed drag rudder installation with servo and pushrods

Note that there are hatches cut in the lower skin, making the whole installation serviceable. You can see the hold-down blocks with screw holes in Figure 41. Also note that most of mid-section of Rib #16 has to be cut away.

Lower Outer Wing Panel Sheeting

Before sheeting the bottom of the outer wing panel:

- Check the spar tongue slots by test fitting a scrap piece of 1/8 ply to ensure they are straight and unobstructed.
- Install 3/32 shear webbing on front or rear spars as desired. It is recommended to install it on the front spars, at least out to rib #15.
- Install the elevon sub-rib 10E. This allows sheeting support for the inboard

side of the elevon. Also install the flap sub-ribs 7F for the same purpose.

- Push a pin through the upper sheeting to mark the location of the rear spar where the elevon will be cut out later. You can make the cut much more accurate that way. Do this also around the elevon servo rails on the inside of ribs 10 & 12. After the wing is done, you can use a long pin to poke through and mark the location of ribs 10 & 12 on the bottom sheeting to facilitate cutting out the access hatch. Do the same for the flaps and drag rudders if you are installing them.
- Check the outer wing panel attachment method and any block installation.
- Make sure you have some way to run the elevon, flap & drag rudder servo wires.
- If you have installed drag rudders, check their installation one more time before sheeting.
- If you plan to install flaps, make sure the flap sub-spars are in place. See the plans.

Sheet the bottom of the wing like you did the top.

Now repeat the whole process for the other outer wing half.

4.6 Wing Tips

Using the supplied laser cut parts, laminate the wing tips and attach. Rough shape the LE, TE and tip.

4.7 Cutting out and Hinging the Frise-style Elevons

Hinges are supplied for a Frise-style control surface. See the diagram on the plans. This style is helpful for this model. The Frise-style elevons aid in turning. By creating drag on the down wing, they help eliminate so-called "adverse yaw" which causes the model to yaw in the direction opposite the turn. Since a flying wing lacks a vertical surface to compensate for adverse yaw, this is the only method. If you're going to fly the model using a bungee and belly land, however, I would recommend conventional elevons. This is because the frise-style elevons protrude downward and tend to catch on the ground. If you use conventional elevons, however, you **must use differential** for the model to turn properly.

Using the plans and/or the marking and wingtip templates for reference, mark the elevon outline on the wing skins. Cut them loose, making the forward cut right at the edge of the rear spar. See Figure 42 and the rib plan for reference. Once the elevon is cut loose, make a second angled cut through through the top surface of the elevon and ribs, further back at the parting line shown on the plans. Sand the cut edges smooth on both the wing and elevon.

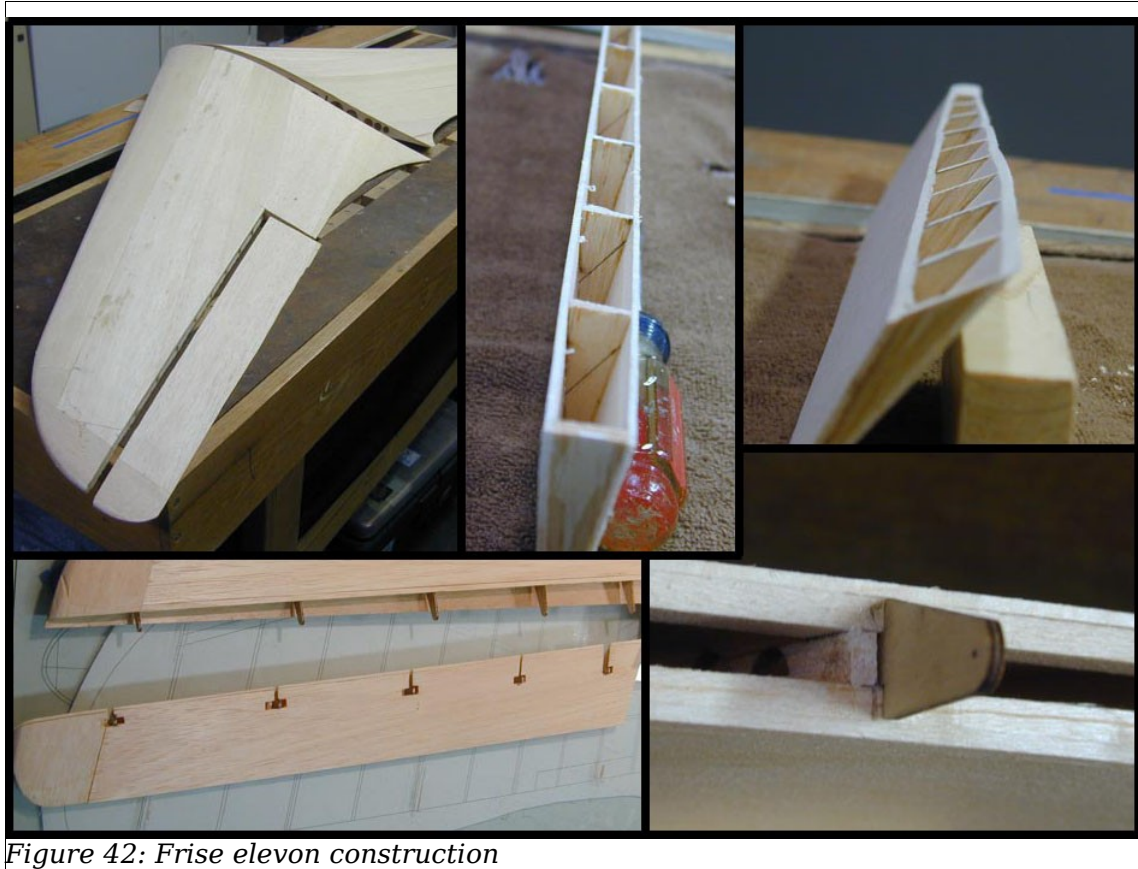

Figure 42: Frise elevon construction

Once this is done you can add the LE sheeting on the elevon. The hinges, made of 1/16" ply, should be reinforced by laminating 3-4 oz. fiberglass cloth or carbon fiber veil on both sides. Carbon fiber veil (tissue) is available from <http://www.cstsales.com>. Test fit the hinges on the wing. You will have to slide these into the wing sideways and then turn them upright against the rib.

You will need to cut slots on the bottom of the elevon to install the hinges. The inboard hinge will also need a slot on the top for the horn. You can offset the hinges on either side of the ribs as shown on the plans, or you can use a 1/16" balsa spacer on either hinge and attach them to the same side of the rib. The latter is probably better. The hinges should be aligned properly and should not need a shaft that goes through all of them. There are many ways to hold the hinges in place. Small holes are pre-drilled by the laser. Cotter pins can be used, or 2-56 screws with nuts. If you choose the latter, secure the nuts with thread locker or they will vibrate loose. Install the 1/64" ply hinge cover on top of the wing to cover the gap left by the elevon hinge area. See the plans.

You can now hook up and test the elevon servo.

4.8 Flap Construction (optional)

Flaps on a flying wing have to be used in either “split” or “crow” mode. Crow mode means that as the flaps are deployed downward, up elevon is required to keep the nose up. This has been tried and found to be ineffective. Split mode is recommended. This means that on each side, one flap goes down and the other goes up. On the prototype, we have the inner flaps going down and the outer flaps going up. This is really just using the flaps as speed brakes. It is effective in slowing the plane for landing. Plan your flap and radio installation accordingly.

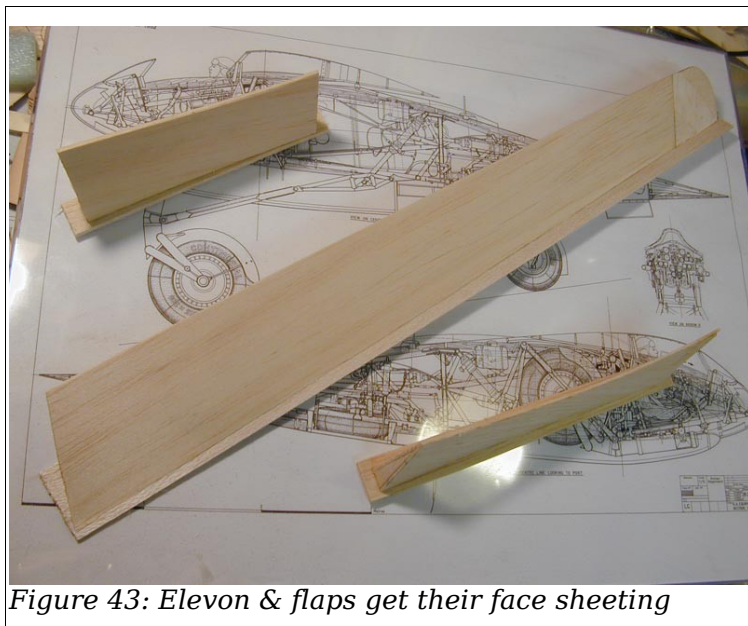

Figure 43: Elevon & flaps get their face sheeting



Figure 44: Flap hinges laminated with carbon fiber veil

Start by cutting out the flaps. You should have pinholes to use as a guide to mark the cuts. Use 1/8 or 3/16 balsa to sheet the faces of the flaps as shown in Figure 43. Laminate the flap hinges with carbon fiber veil as shown in Figure 44

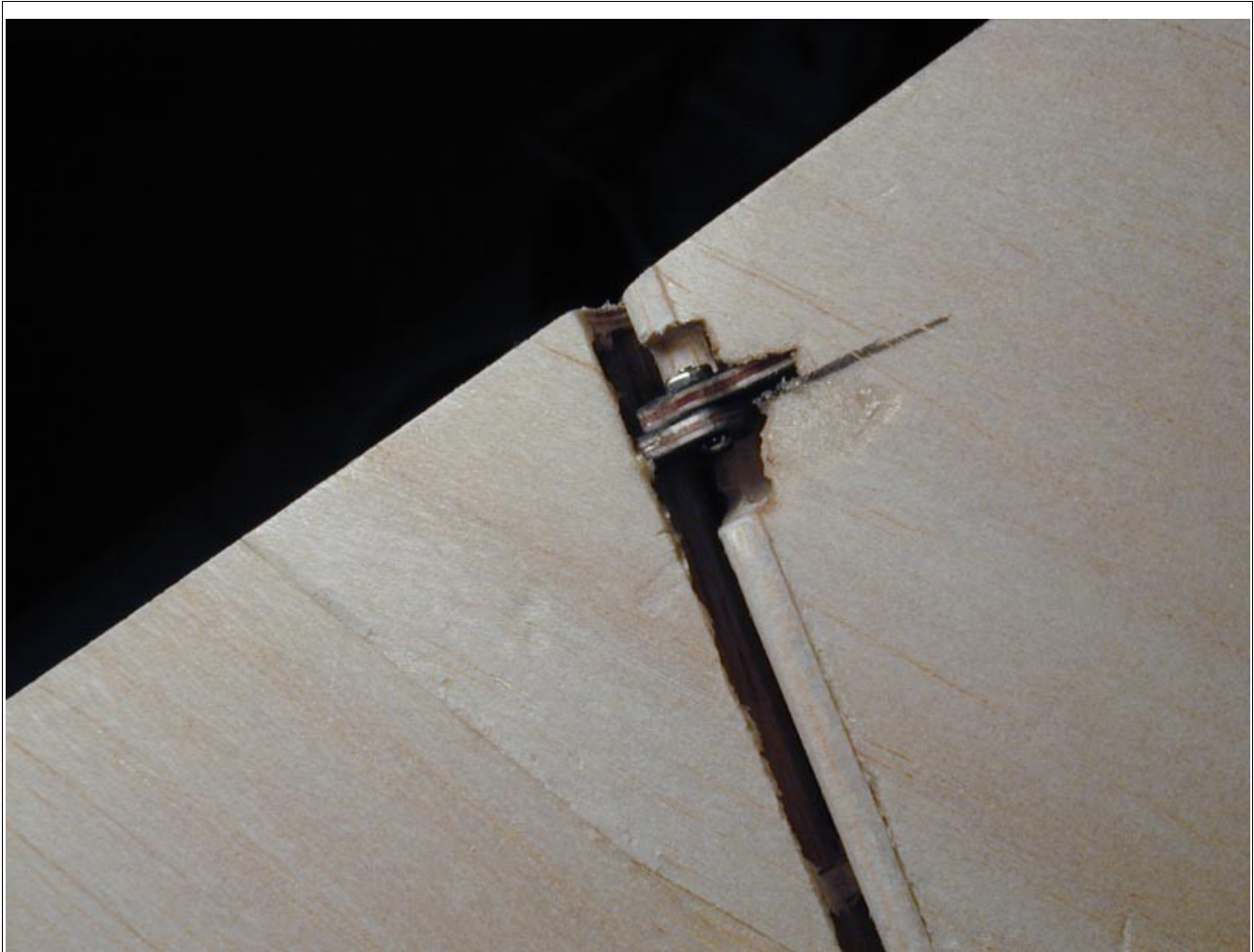

Figure 45: Inboard flap hinge

Glue hinges into the wing and flap, aligning them carefully so the holes and hinge line are true. Secure with a pin or bolt. Check the action and install the servo and pushrod. Remember that the servos should face the same way (right or left) on either wing, not opposed as with ailerons. Otherwise you will need an in-line servo reverser for one of the servos.

5 Closing the center section

5.1 Preparing the center section lower shell

Cut out the intake duct area and mark the duct for filler application like you did for the upper shell. Lay the lower shell on top of the framework. Check the fit and trim the leading edge area if necessary. Glue in at least one of the lower pan support pieces. You will need both of these if you are installing retracts, they support the fiberglass after the main gear doors are cut out. The belly pan needs support even if you aren't installing retracts. If you're not installing retracts, find the weakest part of the pan and glue in one of the supports. Also glue in the small triangular tail cone support at this time.

5.1.1 Nose seam backing

There are two chevron shaped parts on sheet B08, these are for reinforcing or aligning the nose seam between the upper and lower shells (if desired). This area should be reinforced with fiberglass in any case since nose-over (or flip over) is known to happen. Our preference is to reinforce this area with several layers of 9 oz cloth and resin, but the wood parts are provided for those who prefer to work this way.

5.2 Fan Access Hatches

It is easier to cut out the fan access hatches before the lower shell is attached to the framework. The access hatches are cut along scale panel lines except on the outboard side. Cut them out using a hobby knife using multiple passes until you can gently break the hatch free. The hatch can be secured for flight using rare earth magnets, tape or screws. Test fit the fans (with speed controllers) through the holes now. It will be harder to make corrections after the lower shell is attached permanently. See Figure 46.

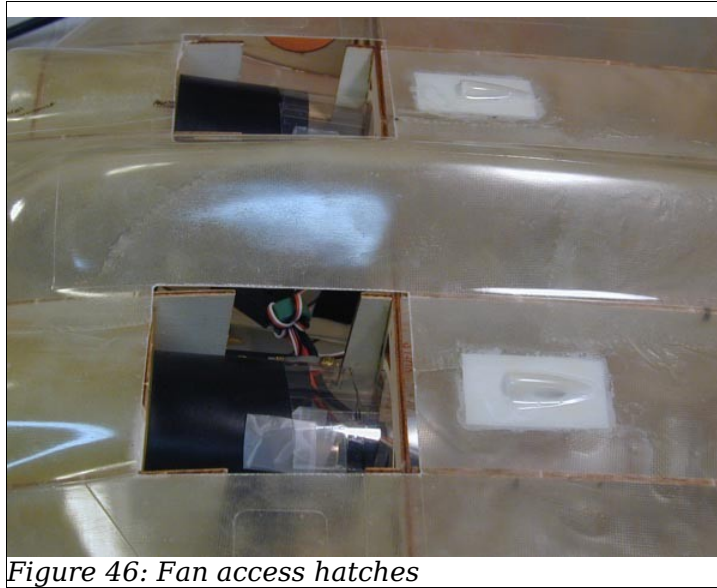

Figure 46: Fan access hatches

5.3 Outer Wing Panel Attachment

At this point, before the lower shell is attached to the center section, you may want to finalize the attachment of the outer wing panels. If blocks or blind nuts need to be secured to the center section, you'll need to do it now while you still have access.

5.4 Attaching the Lower Shell

Check and recheck everything that will be hard to access after the lower shell is attached:

- Have you worked out the rear ducts and their installation/removal?
- Have you worked out the wiring to the elevons and drag rudders?
- Are the outer wing panel attachment blocks or nuts installed? Do the tongues fit into the slots well?

Attach the lower shell using beads of thickened epoxy as you did with the upper shell. Also apply a fillet of micro balloons around the intake duct on both sides as you did with the lower shell. When you're done, the intake area should look something like Figure 47. You can use weights to hold the fiberglass down on the framework. If you do, use the smallest weights possible and use them only over the wooden framework. If you put weights on the open areas, you will cause a "dent" to form permanently in the surface. An alternative is to drill small holes in the fiberglass and stick pins through the holes and into the wooden framework below. The holes need to be the right size to make a tight

'friction fit' with the pins of course. Use some tape on the 'bat tail' area to hold the upper and lower halves together.



Figure 47: Intake duct with fillets

5.5 Finishing the Center Section

When the epoxy is fully cured, remove the center section from the jig. Trim the edges flush with rib 3A. It's advisable to reinforce the inside of the nose area with 2-3 layers of 9 oz fiberglass cloth and resin. This area is bound to take a few bumps and the weight won't hurt anything.



Figure 48: Lower shell attached to framework

Basic construction is now complete. Install the outer wing panels on the center section, stand back and soak it in. WOW!!!

6 Finishing

6.1 Finishing Methods

Since EDFs are still not the most efficient power plants, weight is critical in an EDF model. It is therefore recommended that you consider your finishing methods carefully. For the balsa sheeted parts, a very lightweight filler should be used. The smoother the surface is before finishing, the lighter the finish will be. The following layers are heavier.

6.2 Finishing the Center Section

The fiberglass parts were washed earlier. A final rubbing with steel wool or fine sandpaper (600-800 grit) is a good idea for better paint adhesion. It is recommended to skip using primer on the fiberglass center section. The surface detail will be better preserved if you just give it a light sanding with very fine sandpaper and then paint directly. There should be very few pinholes. Any that are found can be carefully spot filled and painted over.

6.3 Finishing the Outer Wing Panels

We have had good results using Nitrate Dope instead of epoxy and primer for finishing the outer wing panels. This method is much lighter, but still uses ½ oz fiberglass cloth and is very strong. This method is detailed on RCSCALEBUILDER.com in the finishing forum. Keep in mind that the majority of the surface area of the model is **behind** the CG, so the weight of the finish has a big impact on the final weight. Using the nitrate dope method, we didn't need any ballast at all in the nose.

6.4 Paint & Markings

Many different paints can be used. Since this is an electric model and fuel proofing is not required, you might consider using paint for plastic models as these come in very accurate colors and are readily available in any well stocked hobby shop. The Ho 229 V3 was never painted at the factory, but if it had been, it would have most likely been painted in RLM 82 Dunkelgruen upper surfaces and RLM 76 Lichtblau lower surfaces as the V1 and V2 were painted. If the Ho 229 had entered production, it would have most likely been painted in the same colors as other jets of the time, namely a splinter pattern of RLM 81 Braunviolett and RLM 83 Lichtgruen upper surfaces and RLM 76 lower surfaces.

For markings, you can use whatever stick-on markings you can find, but they won't be accurate. I encourage you to use the marking templates supplied. It's a little more work this way, but the results are worth it.

You can just cut these out and use them as masks directly. Just tape and hold them down on the wing and spray the markings on with an airbrush. If you're careful, you'll only get a little over spray which won't be that noticeable from a distance. If you want cleaner lines, a good way to use these is to use 3M 77 spray adhesive to glue the templates to frisket paper or other adhesive backed paper with a low-tack adhesive. 3M 77 leaves a residue, so it is not recommended to use it to attach anything directly to the model. You can then cut through the outlines of the *Balkankreuz* which will yield easy to use (and reusable) paint masks.

7 Trimming for Flight

7.1 Extension Tubes

Extension tubes on the exhausts are required for flight. The exhaust from the EDF units creates a vortex-like turbulent airflow. Since the exhaust exits over the rear of the wing on the Ho 229, this causes a yawing moment and general instability. The first prototype of this model crashed for this reason.

All successful test flying to date has been done with the extension tubes shown in Figure 49. It is hoped they can be reduced in size to be less noticeable, or eliminated altogether with the use of stators. This work has not yet been completed. As you can see from the flight video, the tubes aren't noticeable in the air.



Figure 49: Exhaust extension tubes

7.2 Center of Gravity

The CG needs to be measured and determined carefully. The CG is more sensitive on a flying wing than a conventional aircraft.

It is best to start out with a CG 1/16" - 1/8" forward of that shown on the plans. Be sure to also balance the model laterally. If you have built the model according to plan and your equipment installation is more or less symmetrical, you should not need much lead in the wing tips. If you're putting more than an ounce or two, there is probably something wrong with your balancing method!

7.3 Balancing Method

Do not attempt to balance the model by suspending it from a rope. This method is not reliable. Use a carpenter's square or similar to measure the CG location. Make sure you are measuring from the tip of the nose, parallel to the datum line of the airfoil (the datum line is the line from the leading edge to the trailing edge). Mark the CG location on the bottom of the wing on either side of the nose gear fairing. This should be exactly 13 inches from the nose.

We have constructed a balancing jig which works very well. It measures the CG very precisely and is repeatable. The idea is to rest the model on two pegs at the desired CG point and use the tail as a "meter" to determine the balance more precisely. See Figure 50 for a conceptual illustration.

Measure and mark the CG as outlined above. Drill a small hole on each side. Cut two pieces of 1/2" wooden dowel, sharpen them and make a balancing jig similar to what is shown in Figure 51. The jig (base board) must be leveled in order to make the readings consistent.

The model is very tolerant of a forward CG. You will just have to hold 'up' elevon to keep the nose up which results in increased drag, but otherwise the model will fly fine. Extreme nose heaviness makes the model 'mush', so don't go overboard.

We are still fine tuning the balance of the second prototype, so stay tuned to the Yahoo group and the RCSCALEBUILDER thread for the latest balance info. If you follow instructions to the letter, you should be able to start your flying with a near optimal CG.

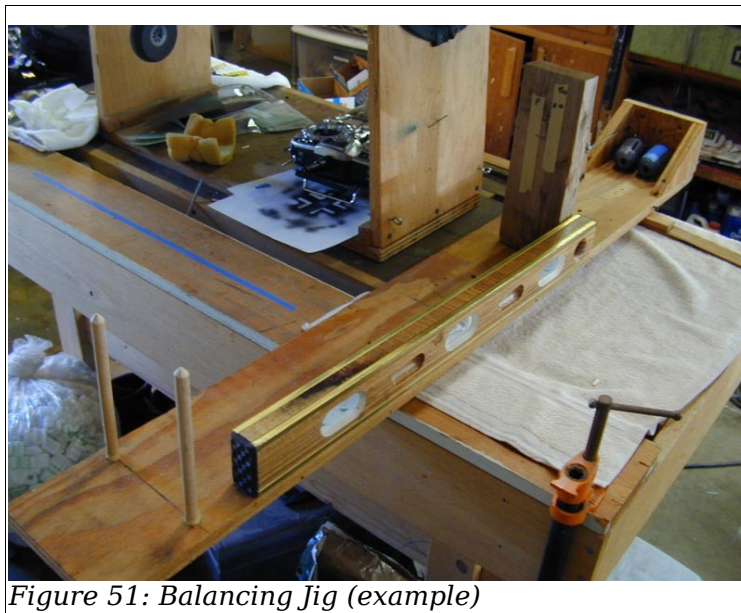
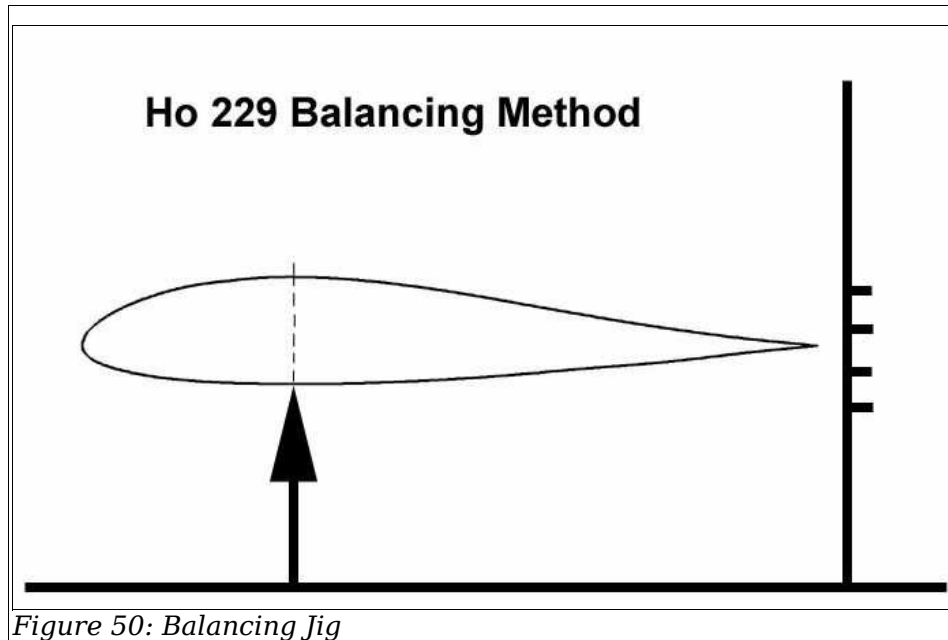

Move the LiPo batteries until the correct fore/aft CG is established. You will be able to tell when you have achieved the correct CG by the trims. The model is balanced correctly when it will fly straight and level at $\frac{1}{2}$ throttle with the elevons neutral to $\frac{1}{16}$ " up. It is best to start with it a bit nose heavy and gradually shift the CG aft. Don't go too far nose heavy though, as the model doesn't fly well if it is drastically nose heavy. You will struggle to keep the nose up and it will "mush" instead of "fly".

7.4 Recommended Control Throws

Start with 1/2" down and 3/4" up throw on the elevons, for both elevator (elevons working together up/down) and aileron movements. You can experiment with varying these, but we have found them to work well.

7.5 Ground Sit (ROG version)

The model should sit with only a slightly positive incidence on the ground. In other words, if you measure from the ground to the leading edge and trailing edge at the outer wing panel break, the leading edge should be only slightly higher, 1/4" or so. The scale ground sit has been tried and found not to work. It causes the model to become airborne too soon and to bounce severely on both takeoff and landing. We suspect this is because the model has much lighter wing loading than the full size.

8 Flying the Ho 229

8.1 General Flying Characteristics

In general, the Ho 229 handles much like any other plane. Though much has been written about instability of flying wings, you will likely be surprised at just how well it flies once it's in the air. The Horton brothers spent many years building and flying pure wing designs. The Ho 229 was the culmination of all of that learning and is an excellent design given what was known at the time.

8.2 Aerobatics

The Ho 229 is quite capable of aerobatics. Depending on power available, the model should be able to do all the basic maneuvers. Riskier maneuvers such as “provoked” spins have not been attempted and are not recommended.

8.3 Bungee Flying

If you're going to fly the Ho 229 with a bungee, make sure you have a field large enough. If you have a clear approach with no trees or other obstructions, the field must be at least 200 yards long. If there are obstructions, it should be 250-300 yards long at least. Assuming you have no speed brakes or flaps, it takes a long approach to slow the Ho 229 for landing.

If you have a field available with tall grass, this can be the easiest way to recover the Ho 229. Just make sure it is thick enough to do the job. If it is sparse you may be in for a hard landing!

Mount your bungee hook halfway between the nose and the CG. Make sure that whatever hook and ring combination you use will separate cleanly on launch. If you're new to bungees, I would highly recommend experimenting with something expendable before launching the Ho 229.

Starting with a few unpowered launches is advisable. For a seven pound Ho 229, we found that 30 lbs pull on the bungee gave a good short glide. For launching with the intent to fly, we used 35 lbs. A marine fishing scale can be used to measure the pull on the bungee. Don't guess!

8.4 Flying from a runway (ROG)

The model should be close to zero incidence while at rest on the ground. If the nose is too high, it will want to fly before it's ready, and it will tend to bounce on landing. Some have devised a variable length nosewheel strut which helps. This allows a negative incidence (shorter strut) on landing, which eliminates the tendency of the model to float or bounce.

8.4.1 Takeoff Procedures (ROG version)

We have discovered that the model needs **full up-elevon during the takeoff roll** in order to relieve strain on the nosegear. If you don't do this, the model is likely to flip over on takeoff. Also, the nosegear is likely to bear side loads. The nosewheel should have smooth bearing surfaces on both sides, either wheel collars or a washer soldered to the axle. This is very important. If the nosewheel binds on any side load, the model is likely to flip over if it veers.

8.5 Approach and Landing

Flying wings such as the Ho 229 have a tendency to “float” on the cushion of air next to the ground (“ground effect”). Plan accordingly and leave yourself plenty of overrun. It's important to bleed off as much speed as you can on approach. Use a gradual descent. Hold the model just off the ground until it stalls. This will require more and more “up” elevon until, by the time you reach stall speed, you should have full “up” on the stick. If you're flying off of grass with no landing gear, this is especially important. If you “fly” the Horton onto the grass, it will bounce and flip over. Damage is usually minor, but you can avoid this with the right approach technique.

It is thought that the scale drag rudders will be useful on approach. They can be mixed with the flap channel and used together as drag brakes. Belly landings would have to be done carefully to avoid damaging the lower drag rudders however. This configuration has not been tested to date.

8.6 More Info

8.6.1 RCSB Thread

Go to <http://www.rcscalebuilder.com> and register. It's free and worth your trouble. Trust me. The Ho 229 thread(s) are in the "Scratch Builds" forum.

8.7 Yahoo Group "Ho229"

Go to <http://groups.yahoo.com/group/ho229/> and join the group. This is a good place to post questions and connect with others building the Ho 229. The building guides are also posted here in PDF format.

8.7.1 Ezone Thread

Paul Sforza, one of the Ho 229 beta builders, has started a beta build thread on the RCGROUPS Ezone: <http://www.rcgroups.com/forums/showthread.php?t=718124#post7863730>

8.7.2 Phone and "Snail Mail"

Finally, if you don't have Internet access and need help, feel free to contact us by letter or phone. The address and phone number are listed on the title page of this building guide.

We have done our best to proofread and test everything that went into this kit. However, errors undoubtedly still exist. If you notice anything significant, please let us know.